

System Catalog 5

Solenoid valves | Process and control valves | Pneumatics
Sensors | **MicroFluidics** | MFC and proportional valves

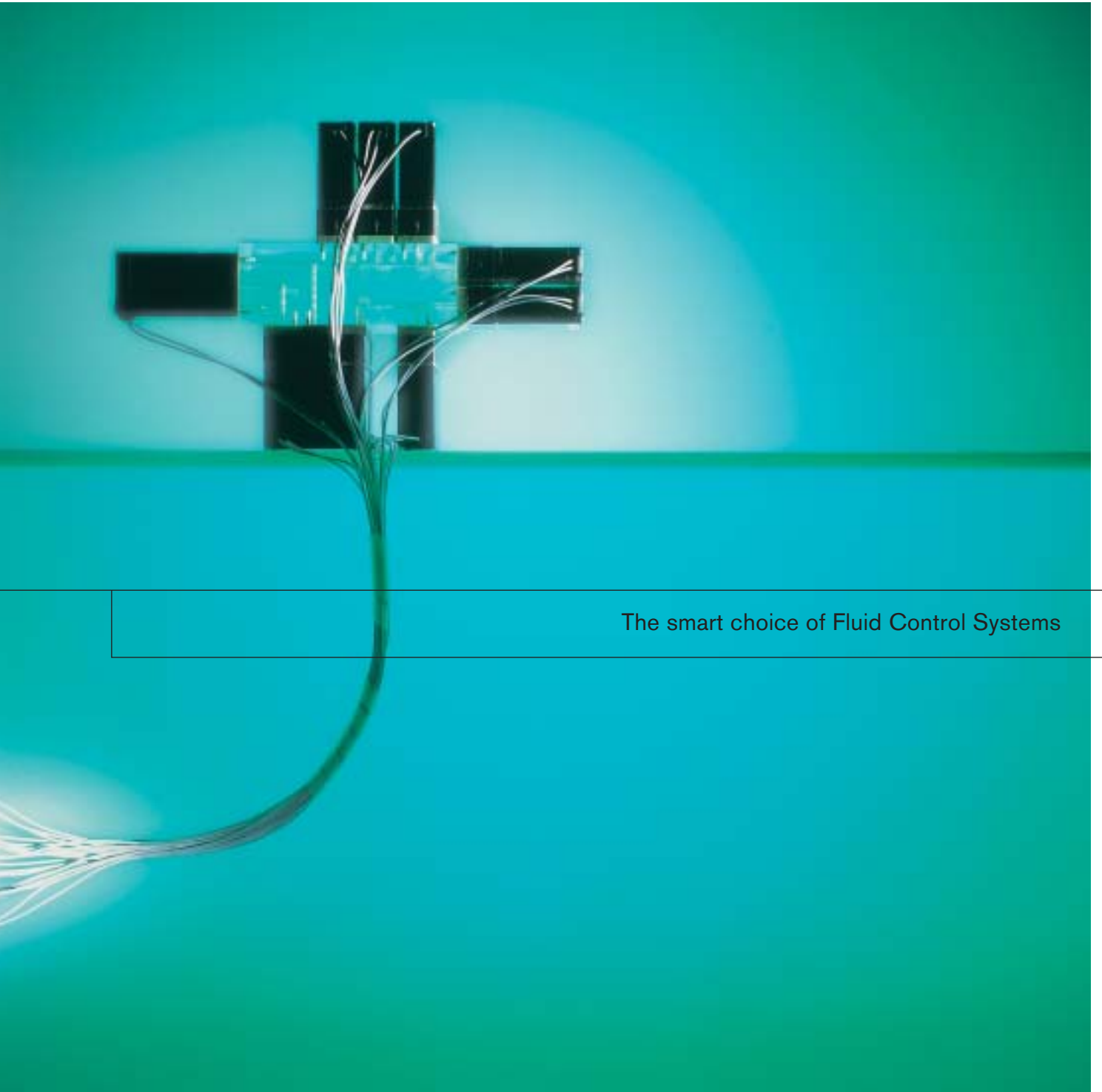

The smart choice of Fluid Control Systems

All technical details were valid at the time of going to print. Since we are continuously developing our products we reserve the right to make technical alterations. Unfortunately, we also cannot fully exclude possible errors. Please would you bear with us when we say that no legal claims can be derived from either the details given or the illustrations and descriptions provided.

Texts, photographs, technical drawings and any other form of presentations made in this publication are protected by copyright and property of Bürkert Fluid Control Systems GmbH & Co. KG.

Any further use in print or electronic media calls for express approval of Bürkert GmbH & Co. KG. Any form of duplication, translation, processing, recording on microfilms or saving in electronic systems are not permitted without the express approval of Bürkert GmbH & Co. KG.

Bürkert GmbH & Co. KG
Fluid Control Systems
Christian-Bürkert-Straße 13-17
D-74653 Ingelfingen

Contents

<u>The smart choice of Fluid Control Systems</u>	Page 6
<u>1. Fluid control in medical technology, analysis technology...</u>	
1.1. Liquid handling	Page 8
1.2. Bürkert MicroFluidics	Page 8
<u>2. MicroFluidics in analysis</u>	
2.1. The analysis technology service provider	Page 10
2.2. Liquid chromatography, HPLC	Page 11
2.3. Mass spectrometry	Page 11
2.4. Electrophoresis	Page 11
<u>3. MicroFluidics in biotechnology</u>	
3.1. Gas mixing for fermenters	Page 12
3.2. Downstream systems	Page 12
3.3. Microreactors	Page 13
3.4. Multi-reaction systems	Page 14
3.5. Flow cytometry, FACS (Fluorescence Activated Cell Sorting)	Page 14
<u>4. MicroFluidics in medicine</u>	
4.1. Kidney dialysis machines	Page 16
4.2. Adsorbers	Page 16
4.3. Cell separators	Page 16
4.4. Infusion units	Page 17
4.5. Anesthetics equipment	Page 17
<u>5. MicroFluidics in genetic engineering</u>	
5.1. What does genetic engineering do?	Page 18
5.2. Polymerase Chain Reaction, PCR	Page 19
5.3. Genomics and proteomics	Page 19
5.4. Biochip analysis	Page 20
5.5. Genetic engineering in medicine	Page 20
5.6. Production of proteins	Page 21
5.7. Production of DNA vaccines	Page 21
<u>6. MicroFluidics in foodstuff monitoring and inspection</u>	
6.1. Transborder analysis	Page 22

<u>7.</u> Bürkert MicroFluidics	Page 24
<u>8.</u> Valves	Page 25
<u>9.</u> Pumps, flow meters and manifolds	Page 32
<u>10.</u> The application-specific solution from Bürkert	Page 36
<u>11.</u> Example applications	
11.1. Application: "gas mixing for small reactors"	Page 38
11.2. Application: "low dead volume mixer/distributor"	Page 40
11.3. Application: "pressure supply, AutoPatch unit"	Page 40
11.4. Application: "dosing head for liquids"	Page 42
11.5. Application: "determining oil viscosity"	Page 44
11.6. Application: "water treatment"	Page 45
11.7. Application: "gas flow control unit"	Page 46
<u>12.</u> Glossary	Page 48

The smart choice of Fluid Control Systems

Your advantage with Bürkert technology

There are only a few white specks on the fluidics world map where a Bürkert solution has not yet been used. And these specks are becoming fewer and fewer with our range of MicroFluidics product and services.

In the same way as the range of applications of fluid control technology is constantly expanding, Bürkert is also expanding its core competence and using the synergy effects of a wide variety of company divisions to meet the new, diversified tasks.

The approaches to solving problems are "fluidic", since in addition to the international experience and know-how of a technology leader, tailored, customer-orientated services are also an essential part of our company.

Depending on the specifics of the problem, it is possible to obtain application consulting for serial production and engineering, in addition to development and production of individual systems. Whether they require single components or system solutions, Bürkert customers can always benefit from inclusive innovation, an approach geared both technically and economically to the future.

New strengths – Bürkert MicroFluidics for medical technology, analysis technology and biotechnology

Along with automation of process sequences, miniaturization of devices is defining the current "trend" in pharmaceuticals, the chemical industry, biotechnology and medical instruments. Controlled and automated handling of ultra-small fluid quantities is in demand. With its MicroFluidic components, Bürkert meets the demand for ultra-

small valves, pumps and flow controllers which enable new processes, e.g. processes in genetic research and pharmaceuticals.

Likewise, successes in biotechnology, genetic engineering and medicine are linked to the use of miniaturized components in workstations and automatic analyzers. Here as well, Bürkert technology makes the small but crucial difference in achieving a growth market with a great future. "What is hot and what is not" – customers throughout the world benefit from the knowledge and experience of a technology leader.

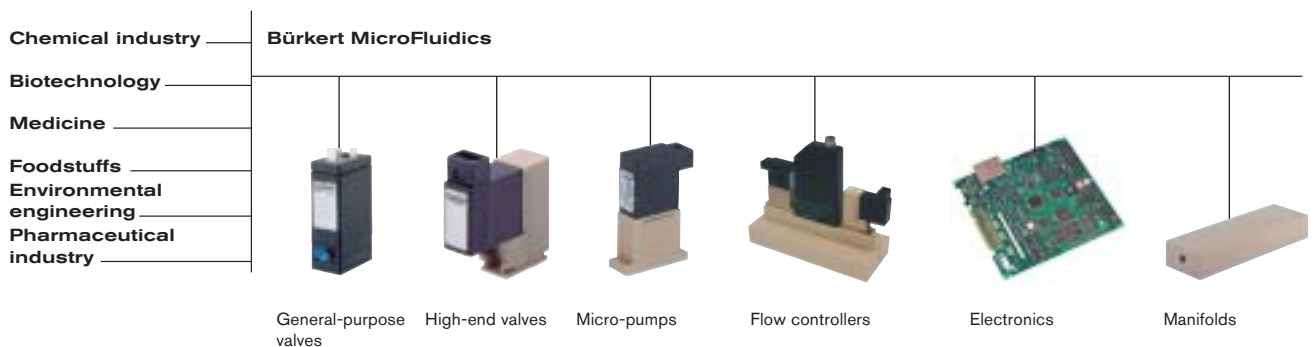

MicroFluidic components



**Bürkert
Ingelfingen headquarters
(Germany)**

- Application consulting
- System development
- Standard component development

Main focal points of competence: medical technology, analysis technology and biotechnology



**Bürkert
Service Center Dresden
(Germany)**

- Electronics development
- System development
- Job-lot and prototype production
- System production



**Bürkert
Gerabronn plant
(Germany)**

- Large-scale serial production and standard device production
- System production
- Electronics development
- System development

Dynamics

thanks to distributed competence

A booming market demands fast and flexible solution approaches. That is why Bürkert has set up regionally distributed competence centers for its customers in the MicroFluidics sector. Customers can make use of the entire range of specific services, locally and in their own vicinity, from application consulting through development to production.

Internal competence and transfer of know-how ensure that the best possible solution is selected in each individual case.

1. Small, strong and flexible

Fluid control in medical technology, analysis technology and biotechnology

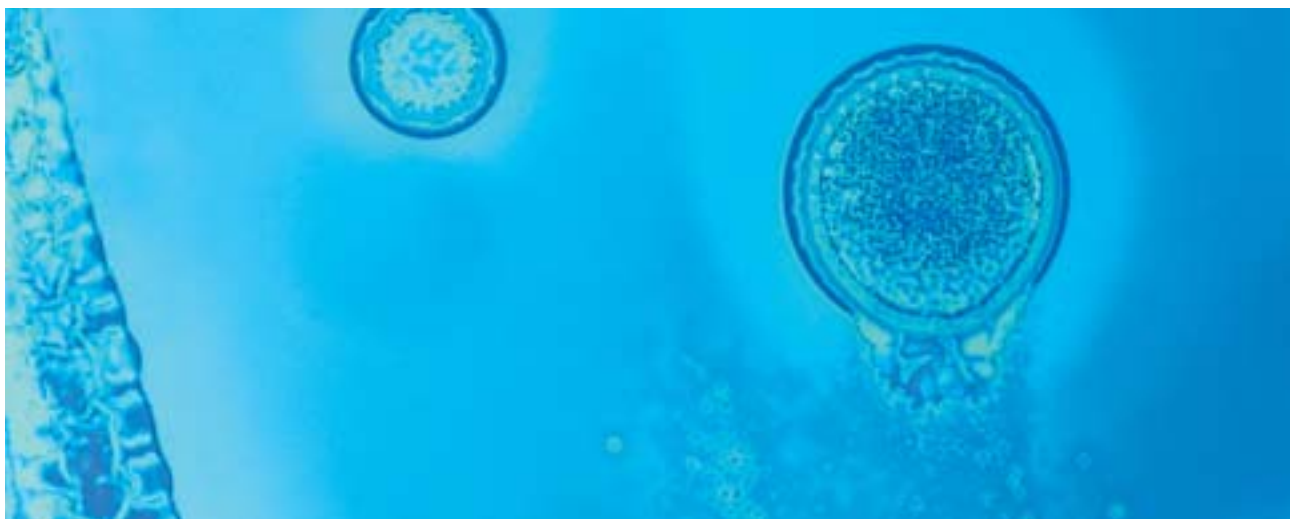

Fluid control ranks as one of the basic technologies in medical technology, analysis technology, biotechnology and related sectors, due to the fact that the substances are primarily present in liquid form, whereby automation and, in particular, miniaturization, are the currently prevailing trends. Existing devices and processes thus become more efficient (faster sequences, higher throughput, lower substance quantities, less solvents and lower costs), and new processes, for example in genetic research (genomics and proteomics) or the pharmaceutical industry, are enabled.

1.1. **Liquid handling**

Liquid handling is the control and automated handling of small and ultra-small fluid quantities in a wide variety of devices and processes. At the same time, it also refers to a sub-function in extensive, modular-structure equipment systems for conducting analyses of all types (screening), for which terms such as workstation or automatic analyzer have also become common. Such devices have become an absolute prerequisite for success in biotechnology, genetic engineering, medicine and other related areas.

1.2. **Bürkert MicroFluidics**

Bürkert has developed an extensive range of miniaturized components (MicroFluidic components), such as

valves, pumps and flow controllers, and the connection manifolds (manifolds) required for setting up the functional units that specifically implement the above trend.

Both the overall dimensions (width per station down to 10 mm) and the performance data (dosing rates down to a few nanoliters) of these components meet the requirements demanded for miniaturization. Components of this size and performance are called MicroFluidic components.

Three essentials for MicroFluidic components

1. Cost-conscious miniaturization

In the fields of application above, a frequent task involves handling fluids that are available only in very small quantities and are very expensive and which, in addition, often cause an aggressive chemical reaction.

Accordingly, the logical requirement is for:

- Small internal volumes and overall dimensions (miniaturization)
- Low dead volume and good flushability (gap-free shaping of the interior)
- Media separation
- Use of inert and resistant materials.

2. Reliable continuous operation

Many applications necessitate operation of devices round the clock to ensure the required high sample throughput.

Accordingly, the logical requirement is for:

- Freedom from wear and tear
- Up to 10^8 valve cycles
- Short valve response times
- Low power consumption.

3. Modular flexibility

The devices constructed using Micro-Fluidic components must perform greatly differing tasks with frequently similar sub-functions, e.g. dosing or mixing, in their overall function.

Accordingly, the logical requirement is for:

- Various body variants
- Interchangeability of components
- Modular system with standard center spacings
- Application-specific additional developments.

Diverse applications of MicroFluidic components in devices and processes	
Anesthetics systems	Gas mixers
Analysis platforms	GC/MS coupling systems
Analysis robots	Gel electrophoresis systems
Analytical multi-test units	HPLC units
Auto-analyzers	Incubators
Automatic filling machines	Industrial inkjet printing
Automatic high-throughput units	Liquid chromatographs
Automatic pipetting units	Liquid handling systems
Automatic screening units	Liquid transfer systems
Auto-samplers	Mass spectrometers
Biochip readers	Micro-arrays
Biology workstations	Micro-reactors
Biomarkers	Multi-reaction systems
Blood-purifying units	PCR systems
Cell counters	Proteomics analyzers
Cell separators	RNA purification systems
Chromatographs	Robot platforms
CIP systems	Robotic systems
Continuous-flow analysis systems	Sample processors
Kidney dialysis machines	Sample purification/upgrading syst.
Diluter	Sample switches
Dispensers	Samplers
DNA analysis robots	Tissue engineering
Downstream systems (cell harvest)	Titration
Flow cytometers	TOF mass spectrometers
Flow systems	Washing devices
Fraction collators	

From A(nalysis platform) to W(ashing devices)

The table above lists the diverse applications, which are discussed in the following by way of example.

.

2. Serving versatile information technology

MicroFluidics in analysis

2.1. **The analysis technology service provider**

Analysis technology (“analysis”) is a scientific discipline that supplies information about material systems (composition and structure) and then processes that information intelligently. Analysis technology is thus information technology with a cross-section function for virtually all natural science and technical sectors, for industrial value-added chains, for research purposes and moreover, for many sectors of public life, such as health, nutrition and sports (dope testing).

The main groups are as follows:

- Chemical analysis
- Biochemical analysis
- Medical analysis
- Food analysis

Rarely conducted as an end in itself, analysis is more frequently a service provider that performs the tasks of others.

In view of the diversity and ever-more stringent demands in regards to detection sensitivity and selectivity, etc., more up-to-date and efficient analysis methods have been developed continually in past decades and implemented in ultra-modern devices for practical application. This development will certainly continue apace, e.g. for proteome analysis, which is currently the focus of in-depth discussion.

Particularly stringent demands are made on the analysis systems in the sectors of medicine, pharmacology, biochemistry and biotechnology. In such industries, it is frequently the case that only very small amounts of the substance in question are available and, in addition, the material may be

extremely costly. Both factors promote the trend towards miniaturization. In addition, the advanced level of automation in analysis systems meets the specific requirements, both for coping with very high quantities of samples (high throughput) and for cutting costs and eliminating sources of error in the case of manual handling.

Largely standardized micro-titer plates (made of plastic) are used as substrates for the sample material for the various applications in analysis technology. These plates are available with 96, 384 and 1536 cavities, each with a capacity of approx. 250 µl. Owing to their standardization, these plates make effective analytical workflow possible, an absolute prerequisite for precise and automatic filling.

Modern analysis technology would be inconceivable without MicroFluidics

The majority of analytical methods require the sample being analyzed (the “analyte”) to be present in a liquid or gaseous state, and the actual detection mechanism generally necessitates prior precise conditioning and preparation of the sample material, above all with regards to the required sensitivity and selectivity.



Specific MicroFluidic tasks and requirements

- Sampling from a container or a sample stream, if applicable with sample switching
- Sample preparation and conditioning (mixing and dilution...)
- Sample transport to the analyzer
- Sample application into the measuring system
- Sample disposal after measurement

Modern analyzers feature a very high level of automation and frequently combine the above processes into one single unit. It is not without reason that the term “workstation” has become the accepted term for such automatic units, primarily in genetic engineering.

2.2. Liquid chromatography, HPLC

“Chromatography” is an umbrella term covering physical methods in which substances are separated via distribution between a stationary and mobile phase. HPLC (High-Performance Liquid Chromatography) is a separating process in which a liquid sample is transported through a stationary phase under high pressure. Depending on the nature of the interaction between the phases and the sample, we distinguish between adsorption chromatography, partition chromatography, ion-exchange chromatography, size-exclusion chromatography and affinity chromatography. The processes of adsorption chromatography and partition chromatography are the chief processes used in HPLC. HPLC uses partition particles with grain sizes of a

few μm ; it thus achieves high numbers of plates or trays, but at the same time, requires a high counter-pressure to be overcome during transport of the mobile phase through the thin separation column (of a few millimeters diameter). All parts must be interconnected without any dead volume wherever possible and must be pressure-stable (up to 300 bar).

An HPLC unit consists of supply unit (mobile solvent reservoir and pump), injection system, separation column, detector, fractionating unit and evaluation system. The sample is initially injected free of pressure into a sample loop. It is then transported into the separation column by appropriate switchover of the eluent stream. The composition of the mobile phase and, thus, its solvent strength parameter is frequently varied during analysis in the case of separation of complex mixtures and in order to shorten analysis time.

Specific MicroFluidic tasks and requirements

- Sample preparation
- Sample transport
- Mixing the eluent
- Disposal of the sample fluid
- Collection of the fractions (in the case of preparative use)

2.2. Mass spectrometry

Mass spectrometry (MS) is a firmly established part of biotechnology, specifically, for example, for analysis of proteomes. It allows unique identification of the proteins after they have been separated or when they are in protein mixtures.

There are a large number of variants, such as:

- Time-of-flight mass spectrometers (TOF), combined with chromatography for removal of non-bound substances on the protein-chip array
- Surface-enhanced laser desorption/ionization (SELDI process)
- Matrix-assisted laser desorption/ionization mass spectrometry (MALDI process).

Progress in MS enables protein and genetic analyses with a high throughput. The speed of these analyses necessitates automation of the entire sample handling process.

2.3. Electrophoresis

This term refers to the transport of charged particles in an electrolyte solution under the influence of an electric field. It is used for analytical and preparative separation of mixtures of dispersed particles, since individual substances feature different migration rates.

3. All about fungi, lightning flashes and cell harvest

MicroFluidics in biotechnology

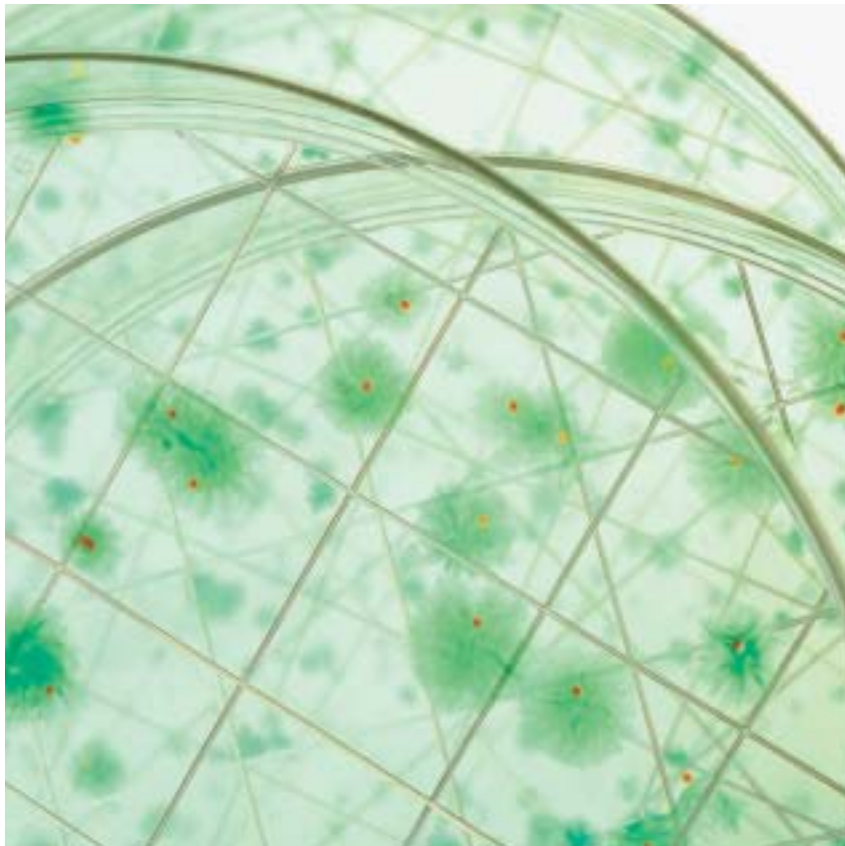

3.1. Gas mixing for fermenters

Biotechnology works with microorganisms such as bacteria, yeast fungi or other fungi, thus allowing the process to run under normal pressure and temperature conditions and in aqueous environments. This is a crucial difference with respect to chemistry where the production processes run subject to high pressures and temperatures and are thus very energy-intensive and frequently include the use of acids or solvents.

However, since the metabolic rates of microorganisms are relatively low, it is necessary to create an environment for them that allows the metabolic process to run optimally. These conditions, some of which are very specific, are created in bioreactors (fermenters), which can be operated intermittently or continuously.

Fermenters are available in an extremely wide variety of sizes, from the bench unit up to building-size reactors for industrial production processes. Parameters for an optimum bioreaction include a defined gas atmosphere in addition to the nutrient content and

pH value (which are adjusted using correction fluids). Oxygen, nitrogen and carbon dioxide in certain mixing ratios, specific to each cell culture, are crucially significant to successful fermentation.

This task is performed by compact gas mixing units, primarily in the case of small fermenters, whose function is ensured by MicroFluidic components.

3.2. Downstream systems

After fermentation (i.e. "downstream"), there is generally a process stage of "cell harvesting" via continuously operating separators. Further purification/upgrading of the products is then performed via diverse filtration and chromatography steps.

This downstream area is also an important application field of MicroFluidic components.

Specific MicroFluidic tasks and requirements

- Simultaneous transport of several gases
- Individual gas mixing for simultaneously connected culture flasks
- Measurement and control of the mass flow rate in the range 0.02 to approx. 50 NI/h
- Pressure measurement (input pressure of the gases)
- Short reaction times, low dead volumes

3.3. Microreactors

There is a clearly recognizable trend in chemistry towards smaller reactors, specifically for research and development, but also for production of fine chemicals with production volumes of a few metric tons per annum.

In principle, microreactors are nothing other than reactors as used in the chemical and pharmaceutical process engineering sectors, but which range in the μm to cm range instead of dm to m range.

Due to their size, they offer certain advantages: for example, they can be operated isothermally despite strong exothermal reaction. This avoids hot spots and means that technical processes can be run at higher temperatures than on conventional systems. Reducing travel, extremely short dwell times, improved heat supply and dissipation and faster response to changed reaction conditions are other resultant phenomena. It is thus possible to achieve enhanced process safety (e.g. in explosion-hazard areas), enhanced process control and enhanced production efficiency.

Despite the compact size, it is certainly realistic to produce several metric tons of fine chemicals in reaction container with a few milliliters volume.

Example applications of microreactor technology are as follows:

- Partial oxidation, dehydration (strong heat tonality, short reaction time, thermodynamically unstable, reactive intermediate as target product)
- Distributed production of hazardous substances (e.g. HCN and HF)
- Implementation in mobile reactors (e.g. methanol reforming)
- Mass screening of catalysts and active substances (small substance quantities)

Specific MicroFluidic tasks and requirements

- Mixing different media in the case of freely adjustable volume flows
- Transport by pumps or pressurization
- Measuring the flow volumes
- Measuring pressure and temperature
- Switching various infeed streams and discharge streams
- Low dead volumes
- Monitoring process parameters

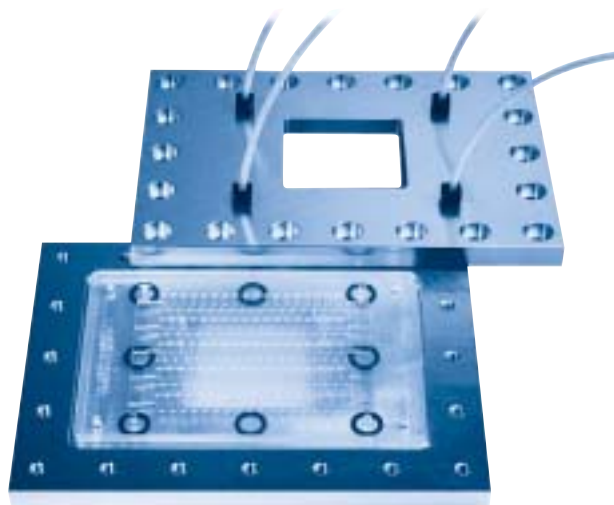

Heat exchanger
5 channels connected in parallel
Fluid 1: $700\ \mu\text{m} \times 1000\ \mu\text{m}$
Fluid 2: $400\ \mu\text{m} \times 1000\ \mu\text{m}$
Heat-transfer layer: $200\ \mu\text{m}$

Source: MGT mikroglass technik AG

3.4. **Multi-reaction systems**

These systems cover devices for simultaneously conducting reactions under individually adjustable conditions such as temperature, pressure and composition. This involves the need for a defined admixing of gases, gas mixtures and/or fluids.

Specific MicroFluidic tasks and requirements

- Mixing different media in the case of freely adjustable volume flows
- Transport by pumps or pressurization
- Measuring the flow volumes
- Measuring pressure and temperature
- Switching various infeed streams and discharge streams
- Short response times, low dead volumes

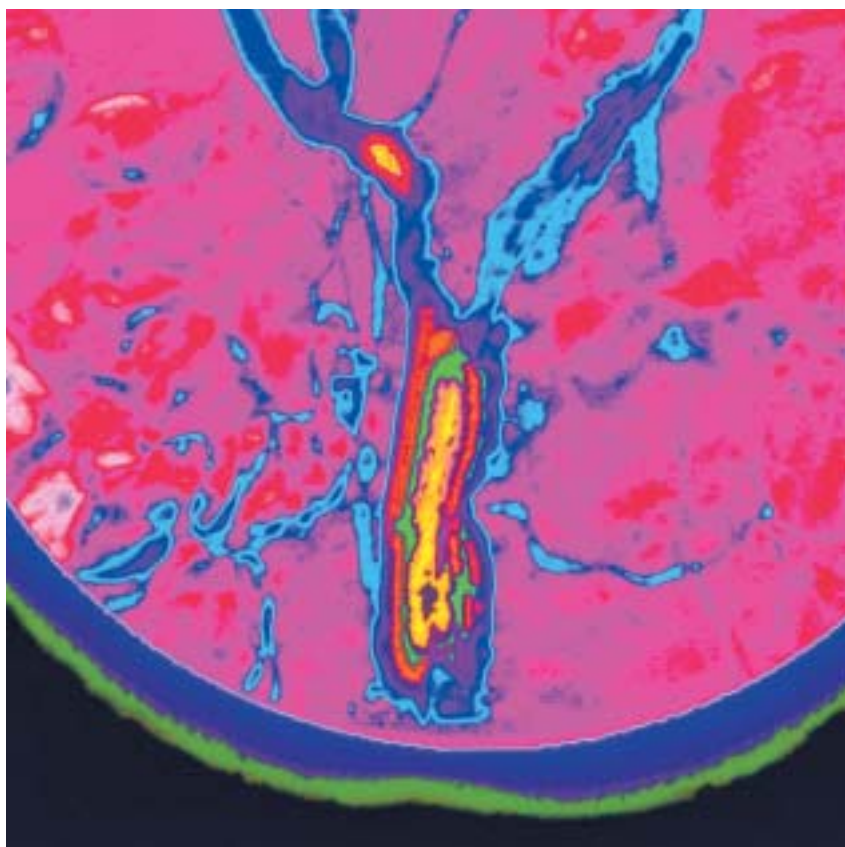

3.5. **Flow cytometry, FACS (Fluorescence Activated Cell Sorting)**

Flow cytometry is a method for counting, sorting and isolating particles (e.g. living cells) which, after being specifically marked with a fluorescent dye, are individually moved past an optical detector system in laminar flow and then counted. By deriving parameters from this counting operation, it is possible to use this method to analyze many characteristics of the particles, whereby the property to be determined can be selected by the specific marking.

One promising, current application is dye marking and isolation of antigen-specific cells within the framework of developing treatment methods for e.g. viral infections or cancer.

The individual steps of FACS:

Using various mechanisms, the cell (to be more precise, a certain subset of it) is marked with a specific fluorescent dye. The individual, marked cells, then present in suspension, are transported (by compressed air) into a capillary and, from there, into the measuring chamber. In this case, an additionally applied sheath fluid comprising degassed water produces a laminar flow which allows the particles to individually pass by the actual measuring point at high velocity.

This is irradiated with a light source (laser), whereby the marked particles passing by generate fluorescent light flashes. By counting these signals, it is possible to determine the flow rate of the cells in question and represent it in histograms.

A piezoelectric transducer allows the cell stream to be split into individual droplets at the end of the measuring chamber. These droplets are electrically charged if necessary, triggered by the corresponding light signal and deflected in a downstream electrical field, thus segregating them off from the stream.

Specific MicroFluidic tasks and requirements

- Supply of the sample fluid
- Supply of the marking fluid
- Supply of the sheath water
- Transport and collection of the sorted cells
- Transport and storage of "waste"

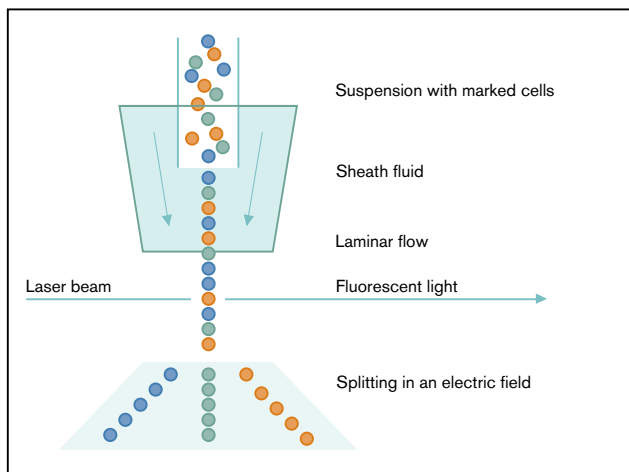

Basic mode of operation, FACS

4. Technology for infusion, hemodialysis and anesthesia

MicroFluidics in medicine

4.1. Kidney dialysis machines

In the generic sense, dialysis is a process for separating low-molecular-weight substances from a fluid by diffusion of these substances through a semipermeable membrane. Use of dialysis in medicine is more than familiar as the principle of the “artificial kidney” for hemodialysis. Similarly, however, dialysis is also used in biotechnology as a “membrane bioreactor” for conducting fermentation processes under specific boundary conditions.

Dialysis in medicine largely replaces the function of the kidney by filtering out water, metabolic end products (e.g. urea) and other toxins from the blood. Blood purification is performed in the dialyser by means of a semipermeable membrane which separates the circuit of the blood to be purified from that of the purification fluid (dialysate). The toxic substances and water from the blood pass through the membrane into the dialysate and are thus removed. The dialysate (deionised water) is enriched with nutrients and its nutrient content, temperature and other parameters are constantly monitored.

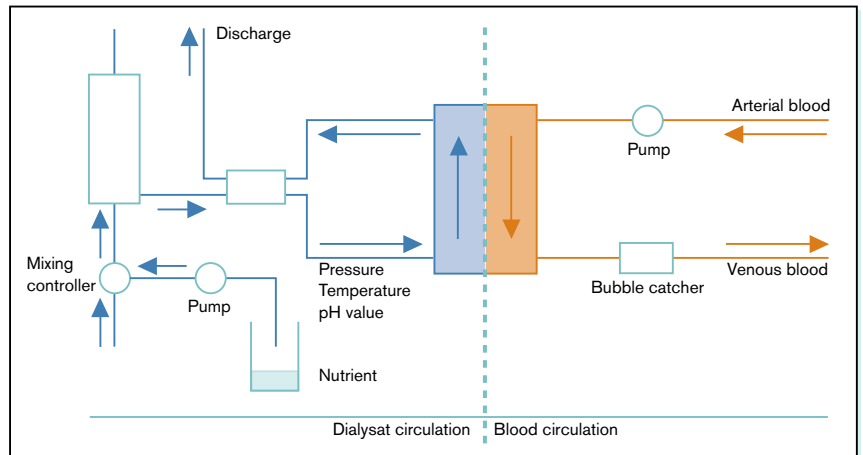

Dialysis process

MicroFluidics, including an automatic control and monitoring system, forms the technical basis of a kidney dialysis machine, whose functions are transport, dosing, mixing, distribution and measurement.

Specific MicroFluidic tasks and requirements

- Circulating the blood
- Transporting the purification fluid
- Dosing the nutrient solution

4.2. Adsorbers

In the case of the adsorber process, pathogenic substances, e.g. cholesterol, are removed from the blood outside of the body. The blood flows out of the patient’s vein into the adsorber in which suitable materials selectively remove the substances from the blood. A special machine ensures that the blood circulates through the adsorber.

4.3. Cell separators

The cell separator is a device for obtaining blood components. Fields of application include removal of diseased cells or blood plasma from a patient’s blood or collecting cells from a patient’s own blood for subsequent back-transfusion.

4.4.

Infusion units

Infusions of fluids in medicine are used for various purposes:

- Compensating for water losses
- Producing/maintaining the normal intracellular and extracellular electrolyte concentration
- Normalizing the acid-base balance
- Covering the energy and protein requirement
- Supplying medications, hormones and trace elements.

In addition to the frequently used gravity infusion method, active infusion units are used as well. Stationary infusion units are used e.g. in operating rooms for "total intravenous anesthesia" (TIVA pump), on intensive-care wards and normal wards (syringe pumps) and in accident and emergency medicine (mainly pneumatically operated pressure infusion units). However, portable systems are also increasing in importance. They are required, for instance, for chemotherapy, analgesic therapy (PCA pump: patient-controlled analgesia), parenteral feeding and for treating type-1 diabetics with insulin pump therapy.



The range of application of MicroFluidics extends from simple systems to highly integrated, closed-loop-controlled systems which operate with flow rates in the ml and μ l range and, in some cases, also in the nl range.

4.5.

Anesthetics equipment

Anesthetics equipment contains all components required for performing inhalation anesthesia, such as gas mixer and gas dosing systems, vaporizers and gas extraction. On modern units aim at achieving a largely closed circuit with a low fresh gas supply that, besides achieving a lower gas consumption, also affords the advantage of lower environmental pollution. The fresh gas supply lies in the range 0.5 to 1 l/min.

5. On better-tolerated vaccines and decoding the human genome

MicroFluidics in genetic engineering

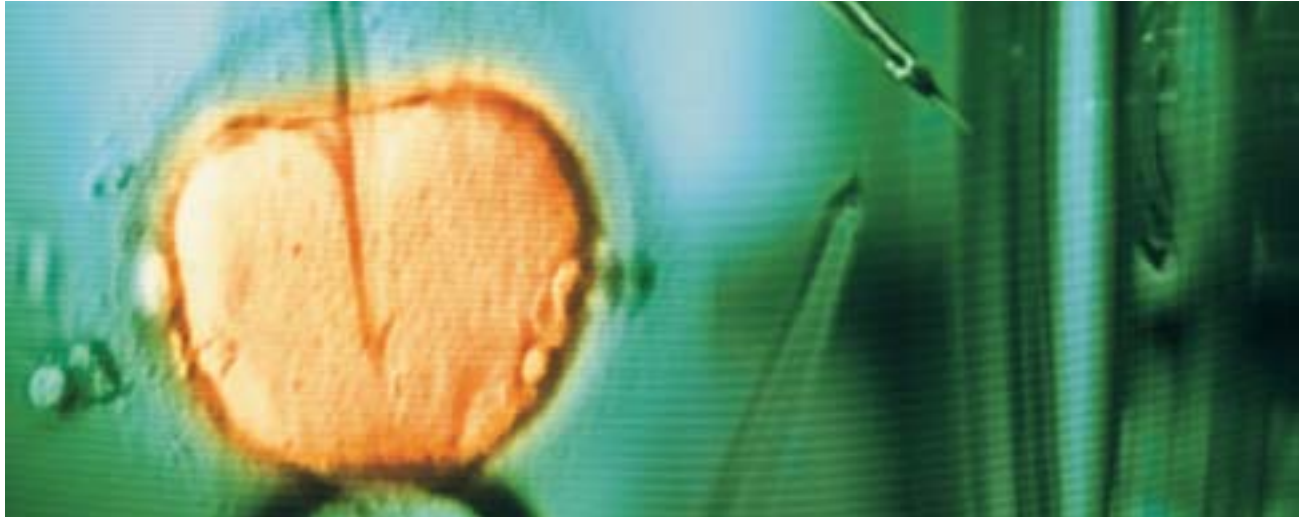

5.1. What does genetic engineering do?

The idioplasm or hereditary substance of virtually all living beings or organisms, from bacterium to humans, consists of double-strand DNAs and is subdivided into sections (genes).

Genes cause the development of a characteristic, in most cases production of a protein. This conversion of a gene into the protein produced by it is performed in two steps:

- transcription (transfer) of the DNA to a "messenger RNA" (mRNA) and
- translation of the messenger RNA to the corresponding protein.

All genetic engineering procedures aim at targeted modification of the hereditary material and subsequent admission of the modified (recombined) genetic material in living cells (host cells) in order to trigger them to produce specific proteins that they would otherwise not produce.

This process can be subdivided as follows:

Step 1

Modification of the hereditary substance is performed with the aid of specific enzymes (restriction enzymes), which are able to dissect the backbone of a DNA at precisely defined positions.

Step 2

In order to recombine the (dissected) DNA, the fragments are in turn bonded together again (with a changed frequency) by special enzymes (ligases).

Step 3

In order to multiply the recombined DNAs, they are transferred to microorganisms, such as bacteria, yeast fungi or cell cultures (transformation). One method of doing this is electroporation or direct injection (if using animal cells).

Step 4

Not all host cells accept transformed DNA. Consequently, a selection medium must be used to separate the transformed cells from the non-transformed cells. This is generally done using specific antibiotics which cause the non-transformed cells to die off.

5.2.

Polymerase Chain Reaction, PCR

A specific DNA quantity is required for DNA analysis. Previously, preparing this quantity from small quantities of biological parent material was a difficult and very time-consuming process. The PCR method, which was invented in 1983, has eliminated this problem since this method allows DNA fragments to be multiplied exponentially, similar to a nuclear chain reaction, in a simple way by passing them through specific temperature cycles. The steps of the cycle are as follows:

- Denaturation of the double-strand DNA by heating to 94 °C. This separates it into individual strands
- Addition of the primers (starters) and cooling to approx. 50 °C. This

causes hybridization of the primers with the ends of the individual DNA strands and prevents the combination of the single strands

- Heating to 72 °C and addition of a DNA polymerase (group of enzymes), among other substances. This supplements the two single strands to form two double strands.

By repeating this cycle in modern automatic machines, it is possible to produce 1 million “copies” from only one starter molecule within approx. 3 hours!

It is only with the aid of this low-cost and effective preparation method that DNA analysis and, thus modern genetic research, has been able to achieve the extraordinary advances it has made.

5.3.

Genomics and proteomics

The term genomics refers to the biotechnology discipline which deals with decoding the human genome. Admittedly, the genes are characteristic and necessary for what occurs in a cell, but proteins are the actual carriers of the cell functions defined by the genes.

Consequently, in order to understand the cellular processes, it is necessary to record and analyze the totality of the existing proteins with their numerous interactions (proteome research, proteomics). The most important instruments of proteomics include the analysis of protein expression, i.e. the number, size and chemical composition of the proteins in a cell. Processes such as gel electrophoresis, mass spectrometry, X-ray diffraction and nuclear magnetic resonance play an important role in this case. MicroFluidics also makes a substantial contribution to technological further development in this sector.

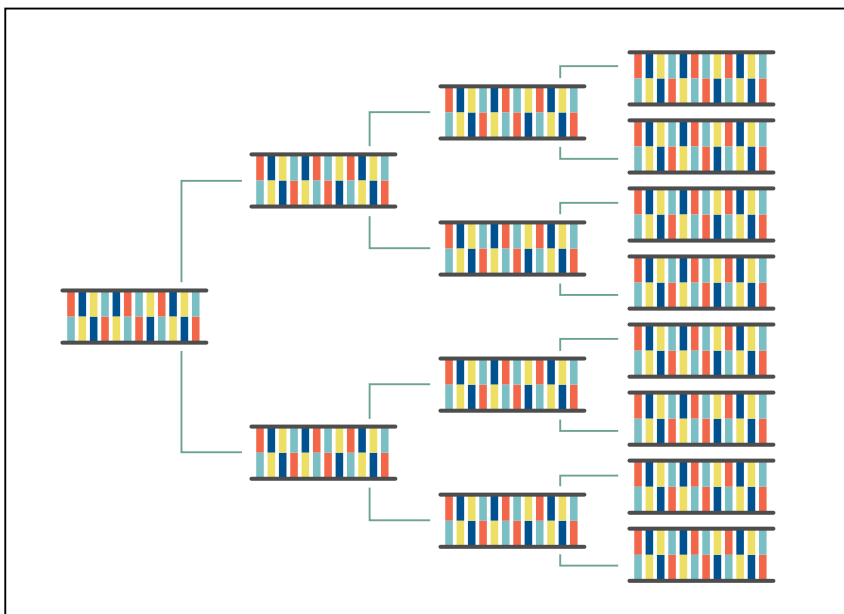

PCR sequence

5.4.

Biochip analysis

This process is a highly innovative method of molecular-biological analysis. Biochips are microscopic slides (generally made of glass or a polymer) on which biological material (e.g. oligonucleotides or cDNA) is fixed in large numbers and with a high density, as a single strand in the form of microarrays, i.e. in a defined arrangement. Such chips perform the function of diagnostic tools and are offered by many manufacturers with various attributes.

In the case of biochip analysis, the substance under investigation, which is also single-strand (e.g. a patient sample or food sample), is brought into contact with the molecules fixed on the chip. If molecules of the sample substance encounter molecules of the chip that are complementary to them, an interaction occurs on the basis of the key-and-lock principle ("precise-fitting parts"), with formation of a double strand (complementary hybridization). This process can be visualized by appropriate pretreatment of

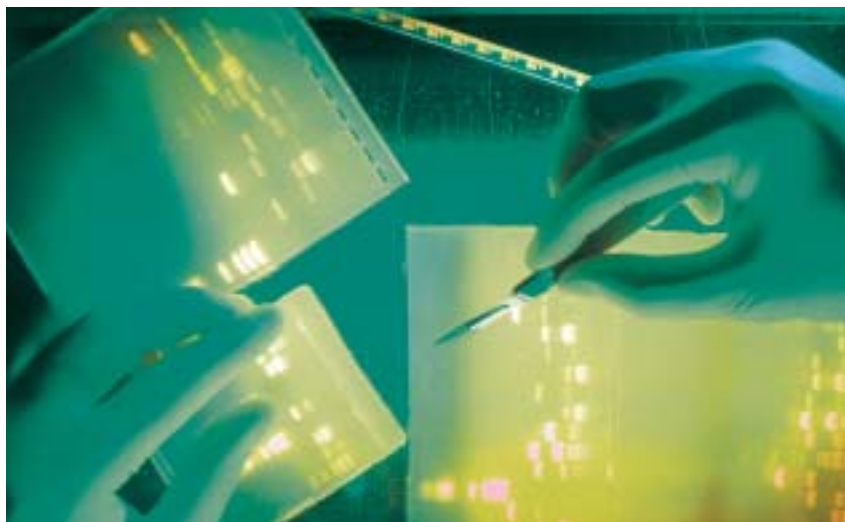

the sample materials with fluorescent dye. The fluorescent pattern thus produced contains the information as to what substances were present in the sample.

Biochip technology has recently also been applied to detection of protein patterns (protein chips) in the cell. In this case, the chips utilize the specific bonding of proteins to interaction partners positioned on the chip. However, this technology is still in its infancy.

Specific MicroFluidic tasks and requirements

- Highly precise dosing on the chip
- Minimal channel dimensioning, freedom from dead volumes and perfect flushability
- Effective hybridization with minimized consumption of costly reagents
- Transportation of the reagents by pressurization through inert gas (to replace pumps)
- Pressure control specific to the various pathways in one unit
- Flow monitoring upstream of the chip

5.5.

Genetic engineering in medicine

Genetic engineering serves as a tool in the production of new medicines and in simple and fast diagnosis of hereditary and infectious diseases. One current example relates to the progress being made in research into the causes of diabetes. A gene has been identified which plays a demonstrable role in the occurrence of type 2 diabetes. On the basis of this, a method has been developed to predict the genetic risk of type 2 diabetes.

One other example relates to production of the substance erythropoietin (EPO), required for formation of red corpuscles and which is produced by the kidney. EPO is present only in extremely small traces in the human body, and that is precisely why genetic engineering methods offer the only possibility of producing this substance in larger quantities and making it available for therapeutic purposes.

A person's predisposition to developing cancer may be of genetic origin and thus hereditary. In this case, genetic engineering can be used to identify genes whose detection would anticipate a probability to develop breast cancer. Here as well, initial approaches have been achieved for corresponding therapeutic options.

5.6.

Production of proteins

A wide range of pharmaceutically active proteins are produced today with the aid of genetically modified microorganisms on the basis of the process steps described above (in refined or extended form). One known example of this is the production of human insulin and the faster-acting analog insulins.

5.7.

Production of DNA vaccines

DNA vaccines offer clear advantages over conventional vaccines (on the basis of inactivated viruses or bacteria). They are tolerated better, cost less to produce and are easier to store. This involves injecting DNA molecules bearing the hereditary information for specific antigens of the pathogen. Today, DNA vaccines are produced on a 10-100 gram scale.

Type 7604
Possible application
for continuous
circulation of the
sample medium in
biochip hybridization



6. Our daily bread

MicroFluidics in foodstuff monitoring and inspection



6.1. **Transborder analysis**

With the increasing practice of intensive farming and innovations in the field of food technology, i.e. genetically modified products and designer foodstuffs, our shopping basket is filled with products that are being more and more critically viewed by the consumer. “Designer” foods, which are intended to enhance well-being and prevent illnesses due to their specific constituents (minerals, vitamins and antioxidants) and other “innovations” increase the distrust of purchasers, who demand that their food contains absolutely no constituents posing a health hazard. Consequently, effective food-

stuff monitoring and inspection are indispensable, not only for consumer protection, but also for manufacturers who endeavor to gain the trust of consumers. In 1999, the European Commission, in a white book, proposed a monitoring mechanism covering the entire chain of production, enabling full-coverage quality analysis from fodder or raw material up to the end product.

This requires powerful examination methods that also have to be harmonized and validated in view of transborder production chains.

Since foodstuffs generally comprise heterogeneous substance mixtures, the individual substances must be analyzed qualitatively and quantitatively, thus placing stringent demands on sample preparation and analysis.

One example is systematic traceability of the origin of meat products. In this case, a digital identity pattern of each animal is created with the aid of genetic analysis; this pattern allows subsequent and clear traceability of the origin of the meat processed. Besides sophisticated sample logistics, this also necessitates highly automated analysis robots with a high sample throughput, which are then integrated into a powerful database concept.

The aim of the checks and inspections is a precise knowledge of the composition of the foodstuff, thus requiring highly sensitive methods of food chemistry and food analysis with respect to the maximum values of contaminants, of which there are generally only traces. The diversity of foodstuffs corresponds to the variability of the methods used, ranging up to mass spectrometry and, recently, also DNA analysis. One special task results from the matrix dependence that frequently occurs in the case of food analysis. Special sample conditioning methods can help in this case, e.g. immunochemical sample conditioning methods.

Specific MicroFluidic tasks and requirements

- Foodstuff inspection: conveying, mixing, distributing and dosing
- Equipment engineering: flushability, operational reliability and purity of the materials used etc.
- Detection of flow rates allows documentation, traceability and quality assurance



Type 6606
Diaphragm valve with
excellent flushability
for use in food science

7. Bürkert MicroFluidics

The products

General product characteristics

The entire MicroFluidic product series meets the special requirements of the fields of application for which it was designed in line with demand. This means:

- Small and standardized installation dimensions for setting up very compact systems
- Small nominal diameters of the fluid channels with a view to the frequently costly media only available in small quantities
- Use of corrosion-resistant materials
- Minimal dead volumes and easy flushability
- Separation between medium and actuator
- Suitability for battery operation

Product range

The MicroFluidic product range covers the following segments:

- Valves of diverse designs
- Gas mass flow controllers
- Liquid and gas mass flow meters
- Micro-pumps
- Manifolds
- Sensors for pressure and temperature
- Electronics.

In addition to the information provided on the following pages, information can also be found in the Bürkert Product Catalog, which we will be glad to send to you upon request.

Note: The sensors for pressure and temperature are procured from relevant manufacturers in accordance with the specified conditions of the application.

Product systematics

The Bürkert MicroFluidic product range is subdivided as follows:

Components

Serial produced valves, pumps, sensors for pressure and temperature, mass flow meters and mass flow controllers



Individual components:
Type 6604

Manifolds and systems

In various designs (standardized and application-specific), for implementing frequently recurring functions, such as dosing and mixing or distribution.

Highly integrated systems

Extensive systems with high functionality bandwidth due to the individual combination of specific manifolds, components, electronics and sensor systems.

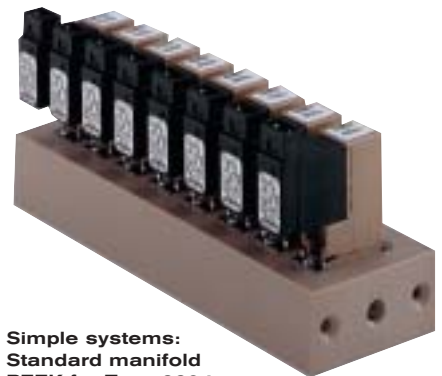

Simple systems:
Standard manifold
PEEK for Type 6604



Highly integrated systems:
Gas flow control unit

8. Valves

What valve meets your needs?

Over 20 different valve types are available. They cover a very broad range of application and thus offer the best possible solution for any specific application task. The valves differ in regards to the following features (see table):

- Circuit function: 2/2-way, 3/2-way and 2/2-way proportional
- With or without media separation
- For neutral, slightly aggressive or aggressive media
- For differing orifices (from 0.4 to 8 mm)
- For different pressure ranges (from vacuum to 10 bar).

Special characteristics

- Very low internal volumes down to 5 μl
- Low dead volumes, frequently absolutely no dead volumes
- Easily flushable inner contours
- High back-pressure tightness
- Suitable for vacuum operation
- Virtually no heat transfer between medium and actuator
- Medium temperature up to 50 or 70 °C
- Frequently very low power requirement and, thus, particular suitability for battery operation.

Flipper valves

On flipper valves, a metal tongue (flipper) vulcanized with elastomer opens and closes the valve seat. Flipper valves allow complete separation of medium and actuator. Compared to diaphragm valves, they produce no pressure pulse when switching and are thus particularly suitable for precise dosing. Less force is required to move the flipper than with the diaphragm valve. Consequently, the response times are particularly short and reproducible.

Flipper valves are insensitive to pressure surges and also withstand higher burst pressures. Since the medium does not act on large areas, the valves remain tight even if a high pressure (back pressure) is applied against the flow direction. Flipper valves have a very long service life owing to the lack of diaphragm flexing.

A flipper valve

- operates virtually free of pulsation
- has particularly short and reproducible response times
- requires very little power
- has a very long service life
- is insensitive to pressure peaks
- is also suitable for highly aggressive media.

Rocker valves

Rocker valves have a diaphragm coupled by a switching rocker that opens or closes two valve seats. They are thus pressure-compensated, in the same way as flipper valves, and also reliably seal off pressures that are applied against the flow direction. The two valve seats and the connecting fluid channel lie in one plane. This means that rocker valves have an extremely small internal volume and virtually no dead volume. The geometry of the fluid channels is designed so that gaps are not produced and to guarantee very good flushability. During switchover, a cross flow is produced between the two valve seats, thus preventing deposits in the valve chamber. If extremely stringent requirements apply to internal volume and dead volume, it is also possible to mount rocker valves directly on user-specific manifolds. The valve seats are then integrated in the manifolds.

A rocker valve

- can be flushed particularly well
- can be flange-mounted directly onto a manifold
- has a minimum internal volume and extremely low dead volumes
- remains tight even in the case of pressure opposite to the flow direction (back pressure)
- is also suitable for highly aggressive media.

Bürkert MicroFluidics valves

	Circuit function			Med. sep.	Medium				Pressure range (bar)				Orifice (mm)			Miscellaneous	
	2/2-way	3/2-way	Proportional	Yes	Neutral	Slightly aggressive	Aggressive	Suitable for vacuum	up to 2 bar	up to 3 bar	up to 10 bar	> 10 bar	< 0.6	0.8 bis 2	2 bis 6	Bistable version	kv value min./max. [m ³ /h]
Type 0124	▪	▪		▪	▪	▪	▪								up to 5	▪	0.25/0.4
Type 0127	▪	▪		▪	▪	▪	▪							▪			0.025/0.06
Type 6604	▪	▪		▪	▪	▪	▪						▪				0.0074
Type 6606	▪	▪		▪	▪	▪	▪							▪			0.025/0.06
Type 6608	▪	▪		▪	▪	▪	▪								up to 3		0.1/0.18
Type 0330	▪	▪		▪	▪	▪			up to 16						▪	▪	0.11/0.29
Type 0331		▪		▪	▪	▪			up to 16						▪		0.08/0.28
Type 6124	▪	▪		▪	▪	▪							▪				0.0074
Type 6126	▪	▪		▪	▪	▪								▪			0.01
Type 6128	▪	▪		▪	▪	▪									▪		0.11/0.18
Type 6104		▪			▪				up to 7				▪				Q _{Nn} max 8.5 l/min
Type 6106		▪			▪									▪		▪	Q _{Nn} max 40 l/min
Type 0121	▪	▪		▪	▪	▪	▪		up to 4						up to 8	▪	0.3/1.0
Type 0330 A	▪	▪		▪	▪	▪									▪	▪	0.11/0.29
Type 6011 A	▪				▪	▪			up to 21					▪			0.045/0.13
Type 6013 A	▪				▪	▪			up to 25						▪		0.12/0.55
Type 2822			▪		▪								0.3-1				0.002/0.02
Type 6021			▪		▪				up to 6						▪		0.05
Type 6022			▪		▪				up to 8						▪		0.1/0.33
Type 6023			▪		▪				up to 4					▪			0.4/0.7



Type 6604

Direct-acting flipper solenoid valve with media separation as 2/2-way or 3/2-way valve with monostable or bistable (pulse) switching function. Fast-switching. Very low power consumption and thus very suitable for battery operation. Minimum dead volume and low-gap inner contour. Width per station: 11 mm. Used primarily for very small quantities of aggressive media.

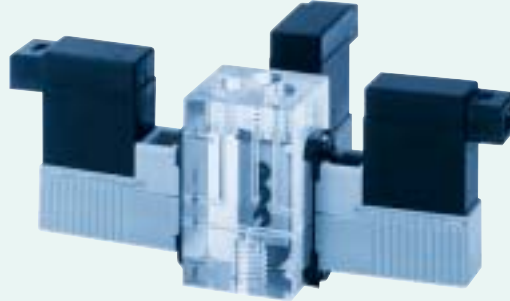

Type 6606

Direct-acting rocker solenoid valve with isolating diaphragm as 2/2-way or 3/2-way valve. With minimum dead volume and low-gap and thus easy-to-flush inner contour. High-quality materials guarantee extreme chemical resistance. The medium only comes into contact with the body and FFKM seal. Coil can be changed easily without having to open the body.



Type 6608

Direct-acting rocker solenoid valve with medium-separated PEEK body with dead volume-optimized and easy-to-flush inner contour. Central screw fitting of the coil allows the coil to be exchanged with the medium applied. Modular body design allows the use of various fluidic connections. For pressures up to 10 bar and orifice DN 3 mm.



Bürkert MicroFluidics valves

	Connectors								Body material								Sealing material								
	Flange	G thread	NPT thread	UNF 1/4-28 thread	M5 thread	Tube spigot	Cable plug	Rectangular plug	Leads	SS	Brass	PPS	PA	PVC	PP	PTFE	ETFE	PEEK	PCTFE	PVDF	FFKM	FPM	EPDM	PFTE	NBR
Type 0124		▪	▪				▪								▪					▪	▪	▪	▪		▪
Type 0127	▪	▪	▪	▪		▪	▪	▪									▪	▪	▪	▪	▪	▪	▪		
Type 6604	▪			▪		▪	▪	▪										▪	▪	▪	▪	▪	▪		
Type 6606	▪	▪	▪	▪		▪	▪	▪									▪	▪	▪	▪	▪	▪	▪		
Type 6608	▪	▪	▪				▪	▪										▪	▪	▪	▪	▪	▪		
Type 0330		▪	▪				▪		▪	▪												▪	▪		▪
Type 0331	▪	▪					▪		▪	▪												▪	▪		▪
Type 6124	▪			▪		▪	▪	▪										▪				▪	▪		
Type 6126	▪				▪	▪	▪	▪			▪											▪	▪		
Type 6128	▪	▪	▪				▪	▪	▪		▪											▪	▪		
Type 6104	▪						▪	▪				▪										▪	▪		
Type 6106	▪						▪	▪	▪			▪										▪	▪		
Type 0121		▪	▪				▪		▪				▪	▪	▪					▪	▪	▪	▪		
Type 0330 A		▪	▪				▪		▪													▪	▪		
Type 6011 A	▪	▪					▪		▪	▪												▪	▪		
Type 6013 A	▪	▪					▪		▪	▪												▪	▪		
Type 2822	▪	▪	▪				▪	▪	▪	▪												▪	▪		
Type 6021		▪	▪				▪		▪	▪												▪	▪		
Type 6022		▪	▪				▪		▪	▪												▪	▪		
Type 6023		▪	▪				▪		▪	▪												▪	▪		

Type 121

Direct-acting 2/2-way or 3/2-way pivoted-armature solenoid valve

The system for separating solenoid system and media chamber consists of an intermediate-vented isolating diaphragm system. Diverse range of applications due to the material selection, including applications involving very aggressive media.



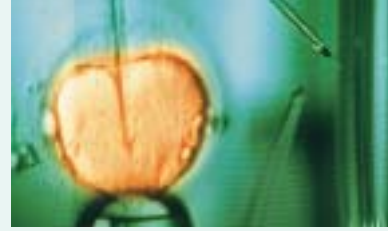

Type 124

Direct-acting 2/2-way or 3/2-way pivoted-armature solenoid valve with isolating diaphragm between solenoid system and media chamber. Available in various materials and with diverse modes of action for opening, shutting off, dosing, aeration or distribution. Particularly used for aggressive, abrasive or lightly contaminated media.



Type 127

Direct-acting rocker solenoid valve with media separation. Developed as minimum-volume, low-dead-volume and easy-to-flush valve (CIP-enabled). An extensive range of bodies allows numerous connection options. All fluidic connections are located in one plane.



Types 330/331

Direct-acting 2/2-way or 2/3-way pivoted-armature solenoid valves
Solenoid system and media chamber are separated by an isolating diaphragm system. The valves are fast-switching and feature a very long service life, even in the case of dry operation. They are particularly suitable for abrasive and lightly contaminated media. Valve 331 is designed specifically for flange mounting.



Types 6104/6106

Direct-acting 3/2-way rocker solenoid valves

without media separation, low power consumption, monostable and bistable drive, body made of polyamide. Suitable only for gases.



Type 6011A and 6013A

Direct-acting plunger-type valves

for high cycling rates (up to 1,000 operations per minutes), production under clean room conditions, including thorough cleaning of all wetted parts to remove inorganic and organic substances. Production and inspection are designed specifically for seat tightness and minimal leakage to the outside (permitted leakage rate 10^{-4} mbarl/sec).



Types 6021/22/23

Direct-acting proportional valves

for continuous closed-loop flow-rate control. Low hysteresis, high reproducibility. Also suitable for technical vacuum in the outlet channel.



Type 6124

Direct-acting flipper solenoid valve, 2/2-way or 3/2-way

with media separation. With monostable or bistable (pulse) switching function. Pulse switching with only 20 ms pulse length and extremely low energy demand, consequently particularly suitable for battery operation. Minimum dead volume and easy-to-flush inner contour. Materials used: FPM, EPDM, PEEK. Use for very small quantities of neutral or mildly aggressive gases and liquids.



Type 6126

Direct-acting rocker solenoid valve, 2/2-way or 3/2-way

A diaphragm separates the medium from the actuator. In addition, the coil and actuator are separated by means of a stainless steel plate. Universal use for applications involving switching small quantities of compressed air or lightly contaminated fluids.

Type 6128

Rocker solenoid actuator with medium-separated PPS body

with dead volume optimized and easy-to-flush inner contour. Central screw fixture of the coil allows the coil to be exchanged even with the medium applied. Modular body design allows the use of various fluidic connections. Type 6128 can be used universally for applications on which compressed air, vacuum or lightly contaminated or slightly aggressive gases and liquids are to be switched.



9. Pumps, flow meters and manifolds



Type 7604 Micro-pump

This micro-pump operates based on the principle of a self-priming diaphragm pump. It was specifically developed for continuous pumping of small quantities of aggressive, inorganic or biological media. Highly precise dosing is possible in combination with an additional flow sensor.

The wetted parts are made of inert and resistant material: PEEK (body) and FFKM (seals). Owing to its resistance, the material combination can also be used for very aggressive media. The temperature of the medium can range from +10 to +60 °C.

The width per station of 11 mm allows an extremely compact set-up, allowing any choice of pump installation position. Owing to the low power consumption of only 1.5 Watt, the pump is also suitable for use in battery-operated equipment.

The delivery rate (max. rate 5 ml/min) can be adapted to the task by varying the control frequency. Virtually pulsation-free dosing is achieved owing to the high maximum permitted frequency (40 Hz).

Pumps		
Micro-pump	Type 7604	Variable control frequency (max. 40 Hz) Virtually pulsation-free dosing Power consumption only 1.5 Watt
Micro-dosing unit	Type 7616	Dosing unit comprising 3 valves and a manifold



Type 7616

Micro-dosing unit

The self-priming, low-dead-volume micro-dosing unit consists of:

- two valves, Type 6604
- one valve 6606
- one manifold (minimized with a view to the internal volume)
- a control circuitry unit (option).

The delivery rate can be adjusted via the number of cycles (max. 650 cycles/min.) and the optionally adjustable stroke volume (0.5 μ l ... 5 μ l). Thanks to the high reproducibility, the unit is suitable for the precise dosing of ultra-small fluid quantities. PEEK and FFKM as the sole wetted materials virtually predestine the unit for use in aggressive media.

Type 8005

Liquid mass flow meter

The mass flow meter 8005 allows fast and precise flow-rate measurements for fluids down to the nanoliter range. Highly sensitive, intelligent CMOSens microchips are capable of detecting the mass flow rate bi-directionally and with media separation through a thin PEEK wall. The high dynamics of this measurement principle allows a measuring range of 5 to 1,500 μ l/min. The accuracy is better than 1.5 or 3 %, respectively, depending on the measuring range, and the detection limit is approx. 150 nanoliters/min.

The device is free of dead volume and its response time, at 20 ms (lower limit), is extraordinarily short. The mounting dimension is 14 mm and the type of protection is IP 65.

The mass flow meter 8005 can be interconnected with other components to form functional modules such as:

- with valve 6604 and the micro-pump 7604 to produce a dosing unit and
- with valve 6604 and the proportional valve 2822 to form a mass flow controller.

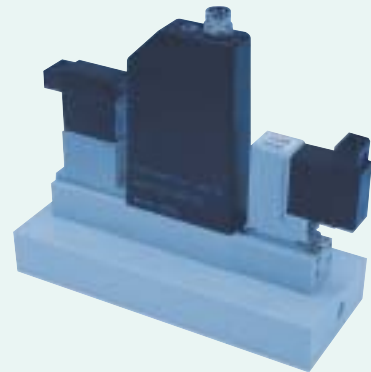

Type 8700

Mass flow meter

Low-cost version. Measuring range 0.05 ... 30 NI/min. (N₂). Digital circuitry with analog or digital interface (RS232/RS485). Sensor arranged in bypass, medium-separated, particularly suitable for toxic or aggressive gases. Accuracy $\pm 1.5\%$ of measured value, $\pm 0.5\%$ of full scale value, option for calibration with N₂ and conversion factor. Fluidic body made of SS, cover made of chromium-plated sheet steel.



Type 8702

Mass flow meter

Measuring range 0.02 ... 50 NI/min. (N₂); digital circuitry with analog or digital interface (RS232/RS485) and optional field bus interface. Sensor (semiconductor element) arranged in bypass in medium. Accuracy $\pm 1\%$ of measured value and $\pm 0.5\%$ of full-scale value. Fluidic body made of SS, cover made of PPS (IP65). Galvanic isolation of inputs and outputs.

Mass flow meters

Liquid mass flow meter	Type 8005	For ultra-small flow rates, max. 1.5 ml/min. Medium-separated, digital interface
Gas flow meter	Type 8700	Measuring range (air) 0.05 ... 30 NI/min. Medium-separated sensor
Gas flow meter	Type 8702	Measuring range (air) 0.02 ... 50 NI/min. Sensor in medium, optional field bus interface

Mass flow controllers

Gas mass flow controller	Type 8710	Measuring range (air) 0.05 ... 30 NI/min. Medium-separated sensor
Gas mass flow controller	Type 8712	Measuring range (air) 0.02 ... 50 NI/min. Sensor in medium, settling time < 300 ms



Manifolds

In addition to customer-specific manifolds, Bürkert offers a selection of standard solutions for Types 6604, 6124, 6126 and 6606. Mixer or distributor functions (2-way) can be implemented via a common collecting channel in each case. The various solutions jointly feature PEEK as the base material and UNF 1/4-28 as fluidic connections, whereby the individual outlet and inlet ports are each in one plane.

Manifolds		
For Types 6604 and 6124 11 mm mounting dimension	2 – 10-fold Standard	All ports in one plane
For Types 6606 and 6126 16 mm mounting dimension	2 – 8-fold Standard	All ports in one plane
For Types 6606 and 6126 16 mm mounting dimension	2 – 8-fold High-end	With extremely low dead volume, direct flange mounting of the valve with seat contour in the manifold, particularly suitable for vacuum, common port at side, individual ports pointing downwards

MANIFOLD

10. Always a unique product

The application-specific solution from Bürkert

Every problem is different

The variety of available components, systems and manifolds from Bürkert is founded on the many decades of experience with products required by the market. This forms the basis for meeting many of the tasks required. In some individual cases, they may not suffice to configure the optimum solution for a specific task.

Individual, application-specific solutions form our concept for technically implementing special requirements with a coordinated performance and service mix. Such solutions frequently comprise systems for standard functions, such as mixing or dosing, combined with specially developed and manufactured components. In most cases, these are individually designed and manufactured connection elements.

resources required for your task in close cooperation with you, the customer.

System partnership

You know what you want. We know what we can do. Close cooperation and continual exchange of information is the course we pursue. Regardless of whether you are an OEM partner who manufactures their own equipment or a "normal" user, in Bürkert, you have

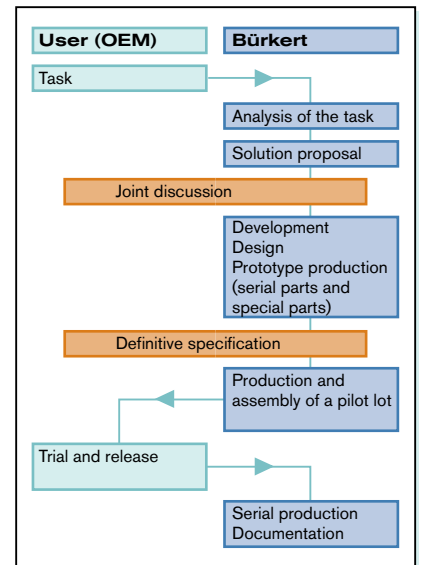
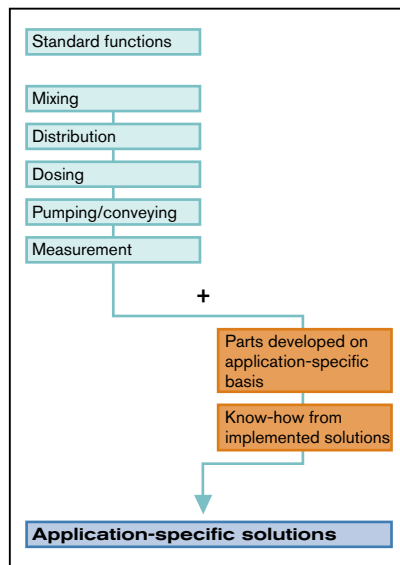

Complete functional unit from a single source: water supply for dentists' chairs

Every Bürkert solution is systematic

When developing new, customer-specific solutions, it goes without saying that Bürkert draws on its comprehensive development know-how, modern production technology, application knowledge and experience from already implemented solutions. But this also involves another factor: the incentive and commitment to utilize all the

chosen the right place for achieving a fast and efficient solution. Generally, it takes only a few weeks to solve the problem.

The project – step by step

The leitmotif of this cooperation: The combination of specific user knowledge with the know-how of an experienced equipment manufacturer.



MicroFluidics production facility in Gerabronn, Germany

Enough of theory, let's talk about practice!

One plant – one promise

Bürkert has set up a production facility specifically for MicroFluidic products where development and production of application-specific systems and serial production of standard components are organized under one roof.

A specially trained, experienced staff, equipped with the know-how acquired over many years, fully concentrates on offering a solution geared towards the needs of the future.

Highest priority: quality

MicroFluidic components would be inconceivable without an optimum standard for production quality. Clean room conditions are just as much a part of this as strict compliance with permitted tolerances. And settings accurate to the μm are an entirely normal step in the production process.

State-of-the-art development workstations

One example of many: a special software package allows the user's only sketchily documented task to be immediately converted, and visualized, to a solution proposal with a 3-D representation. After review, revision and approval by the customer, the same development tool is used to produce a fully dimensioned production drawing.

Tested and approved part for part

Assembly and inspection are performed individually for each part and in directly consecutive operations.

Inspection programs control the sequence and record the values.

In special cases, it is possible to permanently assign the test results to a part and document them. This is one important aspect, e.g., for validation processes.

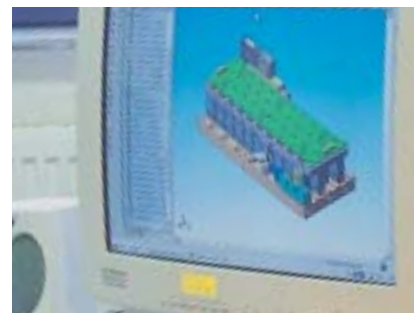

Use of 3-D CAD systems



Maximum precision in assembly



Assembly and inspection workstation

11. Bürkert MicroFluidics: beyond all expectations

Example applications

Provided there are no laws of nature against it, you can expect Bürkert to come up with virtually any possible solution to your specific application problem. That also means that if we bring up what appears to be an unrealizable idea, do not hesitate to ask us about it. There is always a way, especially with the competence of a technology leader!

11.1.

Application: “gas mixing for small reactors”

Field of application

The system serves to simultaneously supply several items of consumption equipment with individually composed gas mixtures from several clean gases or parent gases. It unites all the functions of gas ducting and pressure and flow-rate detection into one compact block. It is used e.g. for calibration units or supplying small reactors of all types.

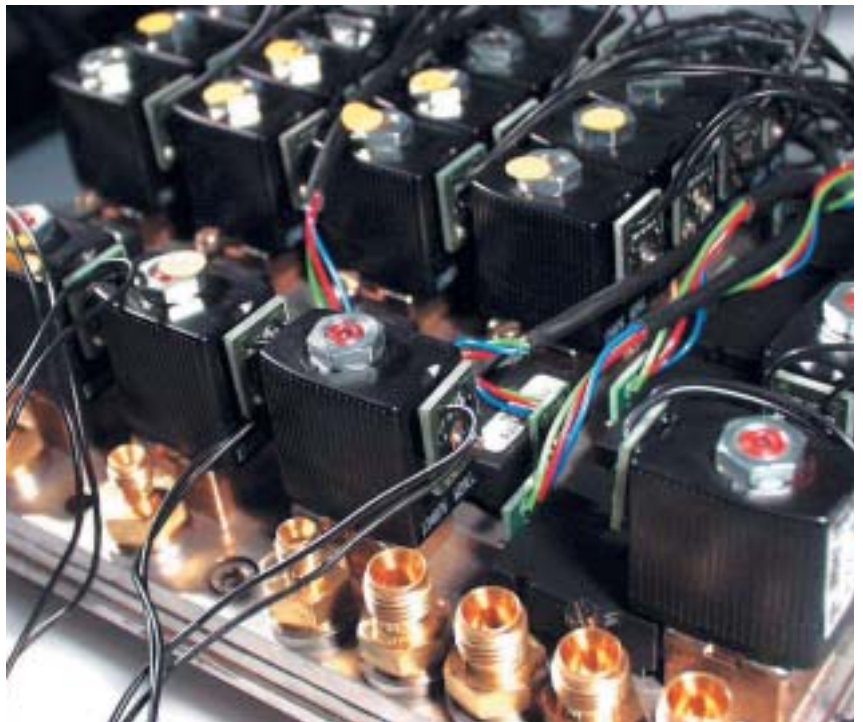

Proportional valves, Type 6021, in the system

Mechanical construction

The system consists of a manifold which is designed on an application-specific basis and incorporates multi-layer technology with 3 layers and various standard components mounted on this. The illustrations below show an example for 3 gases and 3 consumption units.

Characteristics

- Several gas inlets for unmixed gases, e.g. N₂, O₂ or air
- Several gas outlets for mixed gases, each with individual mixing ratios, for simultaneous supply to several consumption units
- Admixing by abrasion-free on/off valves (standard valves 6011)
- Proportional valves 6021 at inlet and outlet
- Mass flow rate controllable in the range 0.5 to approx. 50 NI/h

- Detection of the input pressure of the gases
- Detection of the mass flow rate of gas inlets and gas outlets
- Low dead volumes, compact design and low-wear technology
- Short response times for changing the mixing ratio by entrainment-free

- ducting; mixing is already performed on the manifold by a reservoir between the layers
- Less line-ducting, hose-connection and connection-system complexity due to multilayer manifold.

Gas mixing for small reactors

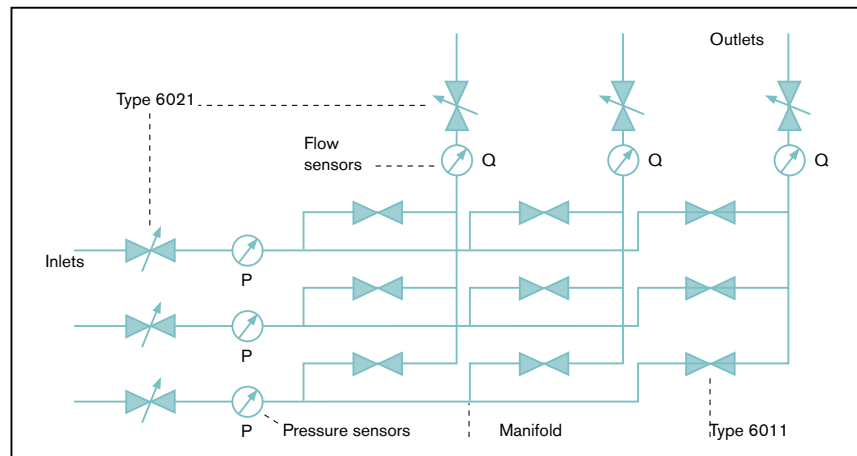

Description/Function	Quantity	Typical characteristic parameters
Manifolds with gas ducting	1	Multilayer technology (3 layers)
Proport. valve, Type 6021, for gas inlet and outlet	6	Low hysteresis for continuous closed-loop flow-rate control
Stand. valve, Type 6011, for internal gas admixing	9	for extremely high cycling rate particularly low leakage rate
Pressure sensors	3	Application-specific
Flow sensors	3	Application-specific



11.2.

Application: “low-dead volume mixer/distributor”

Field of application

In many applications in medicine or biotechnology, it is necessary to feed reaction vessels or measuring chambers with differing media or defined media mixtures following a stipulated time sequence. Switchover between the individual feeding stages should occur without any entrainment effects and flushing operations should be possible.

Mechanical construction

8 valves for mixing and distribution are arranged in a radial pattern, with uni-

formly small connecting channels to the outlet around a central manifold.

Characteristics

- Suitable for neutral and aggressive gases and fluids
- Pressure range from vacuum to 3 bar
- Operating temperature 0 to +50 °C
- Operating voltage 24 V DC
- Minimum channel length the same at all points
- Internal volume (per channel) 5 µl
- UNF 10-32 connections.

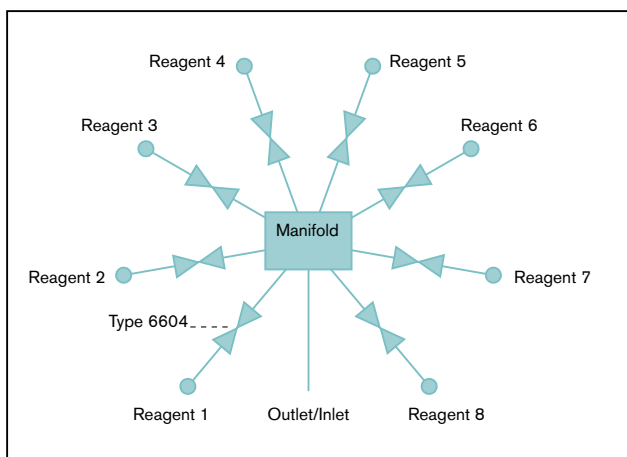

**Fluidic schematic
Low-dead volume
mixer/distributor**

Description/Function	Quantity	Typical characteristic parameters
Manifold	1	Material acrylic or PEEK, 5µl internal volume per channel
Valve, Type 6604	8	Fast switching flipper valve without pump effect when opening or closing

11.3.

Application: “pressure supply, AutoPatch unit”

Field of application

The system serves to provide a defined vacuum for an AutoPatch unit. This allows a significant increase in efficiency in comparison to conventional patch clamp technology in terms of receptor research and medicine development. The electrical signals that are converted by ion channels featuring a receptor function from chemical signals (ligands) are used for this since numerous diseases are attributable to disturbances of ion channels.

The AutoPatch unit isolates a single cell from the cell suspension under examination via an applied vacuum through a channel the size of a few micrometers, passes this over an electrode and thus establishes an electrical connection to the inside of the cell.

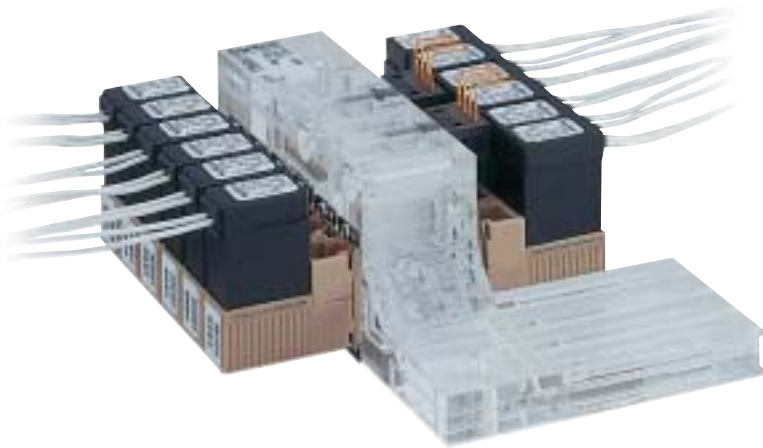

Mechanical construction

The three-layer, diffusion-bonded, multilayer base made of acrylic material guarantees an extremely compact construction. A precisely dosed vacuum or compressed air can be applied to 4 channels per unit. All 4 channels are supplied centrally via one vacuum, with compressed air and atmosphere connection in each case. Vacuum is

“shoveled”, as it were, into an integrated chamber via an interconnected 3/2-way valve, whereby this operation is controlled via a pressure sensor in the chamber. If the required vacuum has been built up, the outlet channel is connected, thus exerting a controlled suction pressure via the electrode onto the medium under investigation.

Characteristics

- Highly integrated functionality in a very compact space thanks to three-layer, diffusion-bonded manifolds
- 36 mm overall width allows butt mounting with micro-titer base center spacing (4 x 9 mm)
- Build-up of precisely defined vacuum is possible with integrated pressure sensor
- Production process (diffusion bonding) ensures dead volume-optimized channel ducting, no entrainment and no swarf or chips in the fluidic chambers
- Transparency allows visual inspection of channels for impurities
- No additional sealing materials required on/in the manifold since sealing is performed by the material connection (no parting lines).

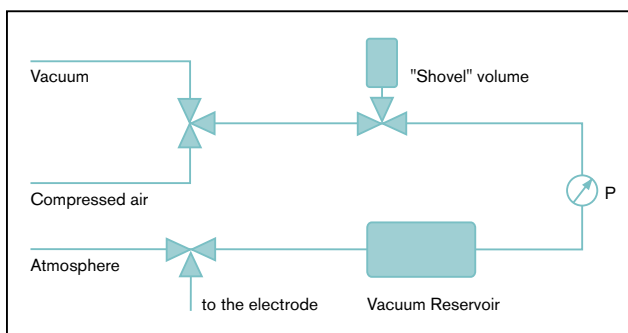

Function schematic for a channel for pressure supply, AutoPatch unit

Description/Function	Quantity	Typical characteristic parameters
Manifold with gas ducting	1	three-layer PMMA multilayer base (diffusion bonded), 4 separate channel ducts
Flipper valve, Type 6124	12	fast-switching 3/2-way valve wetted materials: PEEK and FPM
Pressure sensor	4	uncalibrated, non-amplified ± 1 bar, repeat accuracy ± 0.15 % Span

11.4.

Application: “dosing head for liquids”

Field of application

The “dosing head” system is used e.g. for filling stations or dispensers. On account of its compact design without traditional piping, the manner in which it performs dosing without switchover operations for filling and its optional quantity determination function using a flow sensor (mass flow rate which can be documented), it forms an interesting alternative to traditional syringe pumps. Diverse utilization of the principle in automated devices of all types, e.g. for filling micro-titer plates.

Mechanical construction

The system consists of a manifold designed on an application-specific basis and Type 6604 valves mounted on it, optionally with Type 8005 flow sen-

sor as well. Alternatively, it is possible to work with micro-pumps, Type 7604, instead of valves, thus eliminating an external pressure supply due to self-priming. Since the design of the nozzle is crucial to precise dosing and for preventing droplet formation at the nozzle, Bürkert offers a wide variety of possible alternatives, ranging from stainless steel cannulas to ceramic nozzles to photolithographically manufactured micro-nozzles with a customer-specific layout.

Characteristics

- Arrangement (4.5 mm spacing) allows micro-titer plate dosing
- Constant dosing readiness from a pressurized supply vessel
- Without pressure supply vessel if using a micro-pump
- No switchover operation required for filling
- No piping
- Flow rates in the nl/min to ml/min range
- Flushing in-between can be implemented simply
- Optional control loop with flow sensor
- Sensor with media separation
- Dosed quantity can be documented.

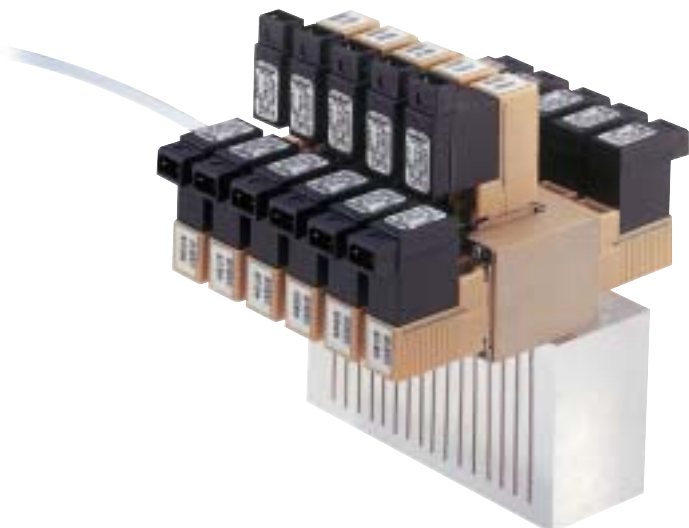

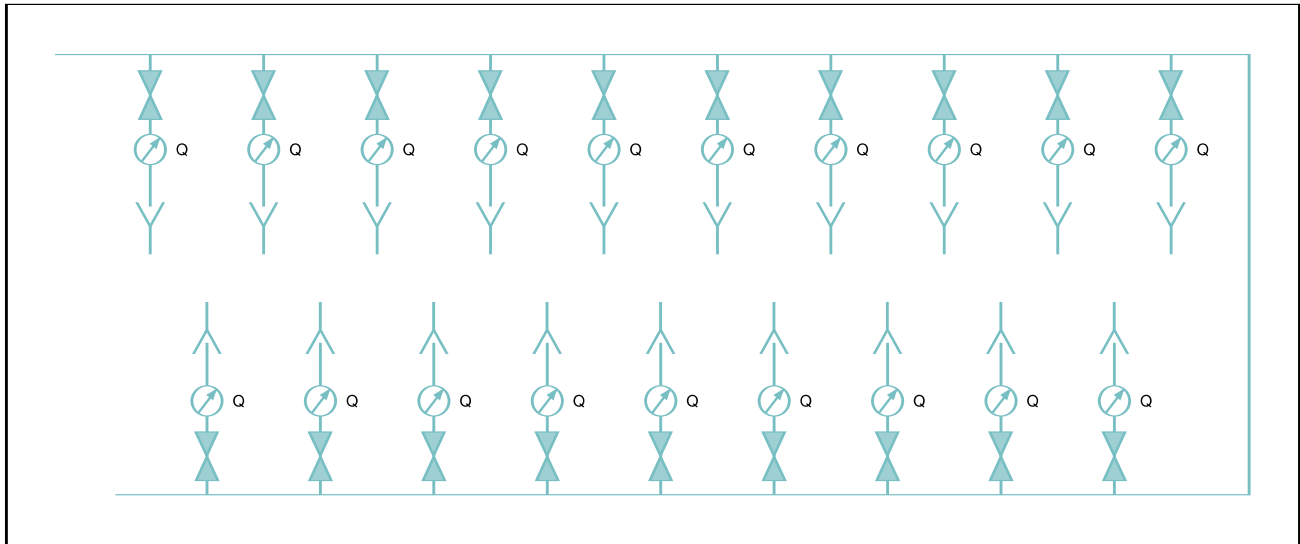

Flowchart for dosing head for 16 channels with flow-rate metering

Description/Function	Quantity	Typical characteristic parameters
Distributor, manifold	1	1 central inlet, 16 outlets lined up with 4.5 mm spacing, material: PEEK
Flipper solenoid valve Type 6604	16	fast-switching, wetted materials: PEEK and FFKM option for PC board contacting
Dosing needles	16	press-in stainless steel cannulas ID 0.3 mm, optionally other nozzle types available
Optional Liquid mass flow meter Type 8005	16	fully media-separated measuring method (only PEEK as wetted material), thermal measuring principle, measuring range down to 1.5 ml/min with dynamics 1:200, smallest detectable quantity 20 nl

11.5.

Application: “determining oil viscosity”



Field of application

The set-up performs the task of the entire fluid handling for automated viscosity determination of oils. The measuring instrument contains two multi-range viscosimeters. Over those, the Bürkert system applies a certain vacuum to suck in the oil to be analyzed. The sample remains in the viscosimeter until the tempering period has elapsed and then drains off freely. The discharge time is measured thermally by NTC sensors and the viscosity is determined. The Bürkert system is also used for multi-stage capillary cleaning in which even aggressive solvents such as acetone or toluene are used. Up to 20 measurements per hour can be conducted, allowing for the discharge times.

Mechanical construction

The system consists of a bolted, two-layer manifold and 9 3/2-way Type 6606 valves mounted on it. The self-draining, dead volume optimized channels are produced by machining at the interface of the bases and are sealed by a fitted FFKM diaphragm. The two separate metering sections can each be supplied with vacuum or gauge pressure. Supply of two solvents is available for automatic cleaning of the viscosimeter.

Characteristics

- Less line-ducting, hose-connection or connection-system complexity owing to multilayer manifold
- Optimized, self-draining channel ducting with 90° suspended set-up
- Electrical contacting via plug-in contacts on a PCB.

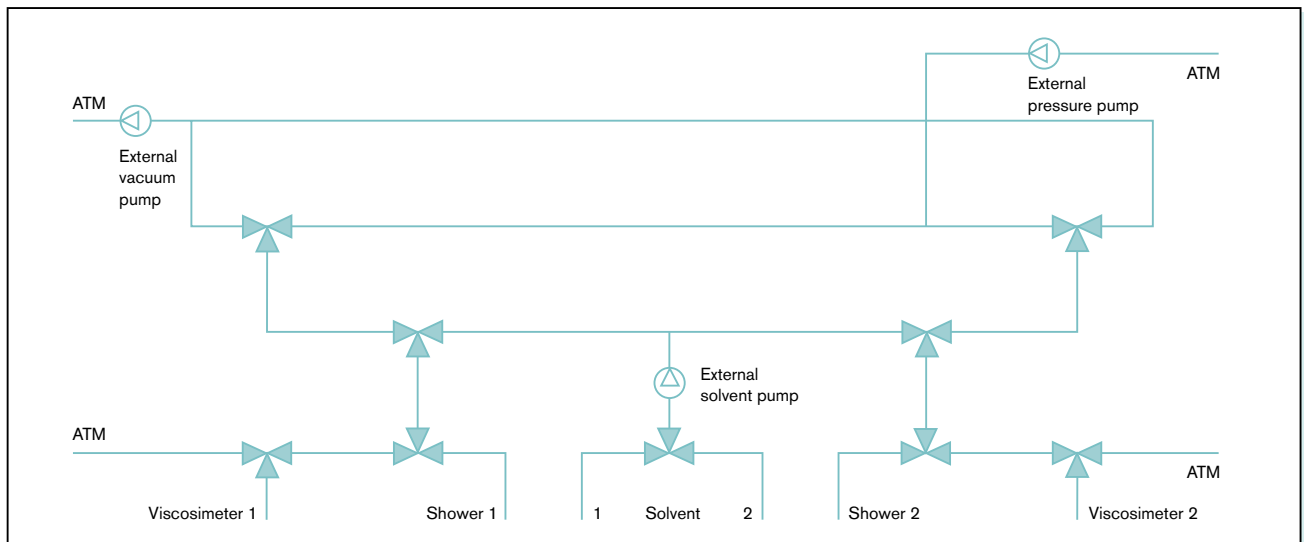

Function-schematic, fluidic handling for automated viscosity determination of oils

- Fluidic connections in two opposite planes, mounted to the back panel of the viscosimeter which accounts for low hose connection complexity
- Media-separated valves and high-quality, inert materials allow cleaning of the system with aggressive solvents.

Description/Function	Quantity	Typical characteristic parameters
Manifold	1	2-layer multilayer base made of brass with FFKM diaphragm as seal
Solenoid valve, Type 6606	9	Medium-separated 3/2-way valve with device plug connection pointing upwards for direct PCB contacting
Hose connections for pumps, showers, solvents and viscosimeter	8	Press-fitted brass hose connectors



11.6.

Application: “water treatment”

Field of application

The valve manifold system is a part of a device to produce and dose deionised water. The device is primarily used in genetics and biology laboratories. In this application, it serves as an ultra-pure water source for steam generators, autoclaves and glassware washing machines. The Bürkert system is positioned as a compact unit directly in the dispenser.

Mechanical construction

One valve, Type 6128, and one valve, Type 6126, are positioned in compact form on a manifold made of acetyl. The two valves are connected in parallel in the manifold providing the user with the option of selecting the right flow rate from three flow rates for their application. Customer-specific cartridge connections are incorporated in the manifold for connection of the inlet and outlet.

Characteristics

- Compact mechanical construction
- 3 selectable flow rates
- Pre-assembled and pre-tested
- Customer-specific cartridge connections
- Low internal volume
- Low weight.

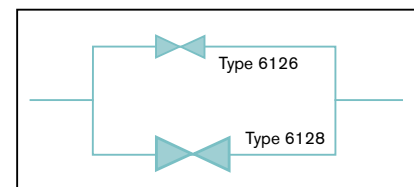

Parallel connection for 3 flow rates

Description/Function	Quantity	Typical characteristic parameters
Manifold	1	The material is acetyl. Both valves are connected internally in parallel.
2/2-way valve, Type 6128	1	Orifice 3 mm; k_v value 0.18 m ³ /h PPS body and EPDM seal
2/2-way valve, Type 6126	1	Orifice 1.2 mm; k_v value 0.03 m ³ /h PPS body and EPDM seal

11.7.

Application: “gas flow control unit”

Field of application

The gas flow control unit was developed for use in ICP spectral analyzers. This analysis method operates with inductively coupled plasma (ICP) for determining trace elements with spectral lines in the vacuum-ultraviolet spectral band (125 to 190 nm wavelength). The system controls both the plasma flow and the cooling, in addition to two optional gas admixing processes for use of biological media (4 argon controlled systems).

Mechanical construction

The unit consists of a microprocessor, pressure sensors and pressure switches, solenoid valves for switching the gas and for venting system sections and proportional valves for continuous closed-loop control of gas streams.

All connections of the fluidic components are integrated in an aluminum manifold. The processor kernel serves as the internal central control unit and as an AD-DA converter for set-point and actual values. The implemented firmware can be read or updated via an additional PC interface.

Characteristics

- Compact overall size (200 x 170 x 100 mm)
- 4 different control ranges for cuvette cooling, for the reactant gas, for the nebulizer and for the additional nebulizer (min. 0 to approx. 1 Sl/min., max. approx. 5 to 20 Sl/min.)
- Optionally intrinsically safe via integrated software and hardware monitoring
- Modularity allows adaptation to various control ranges and numbers of control systems
- Calibration of the sensors in accordance with measuring range and accuracy requirements
- Integrated processor kernel as communication interface and internal central control unit
- PC interface for downloading/updating the firmware
- Control of volume flows instead of mass flow rates.



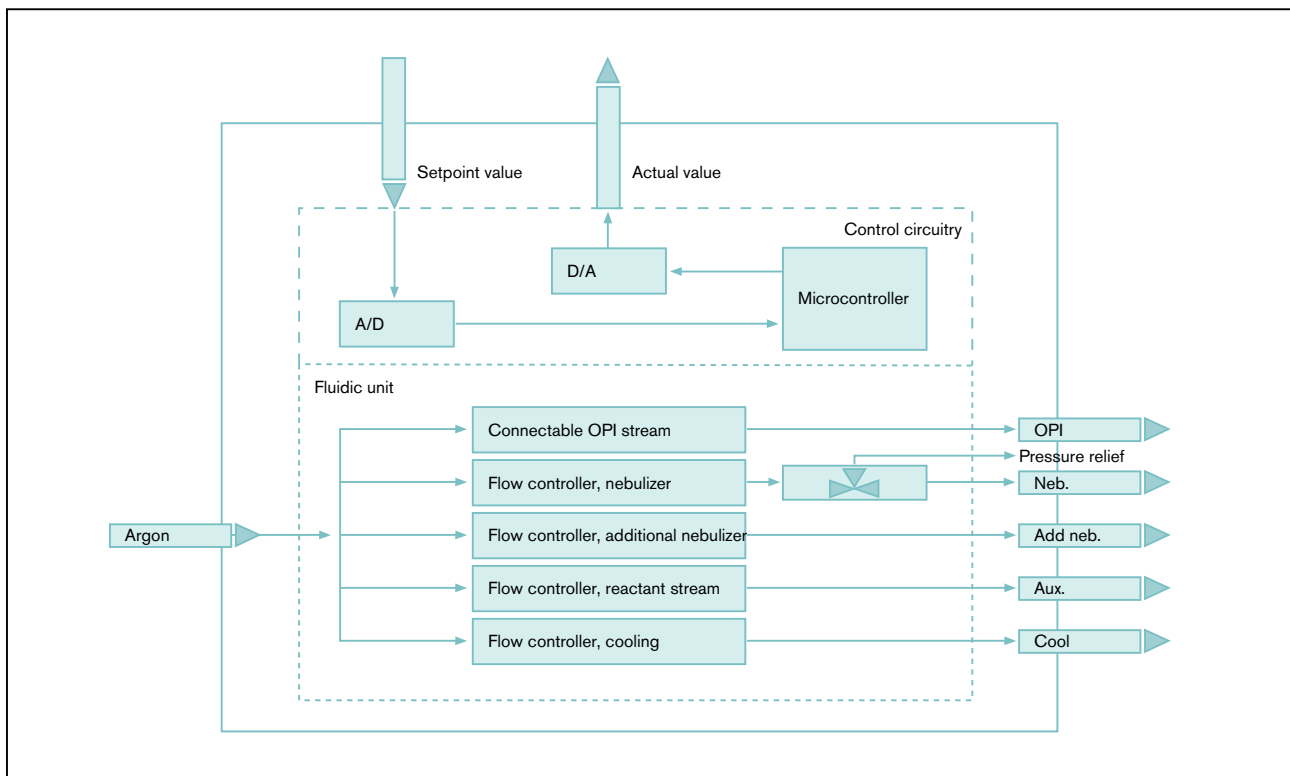

Schematic, gas flow control unit

Description/Function	Quantity	Typical characteristic parameters
Manifold	1	Aluminium, channel ducting produced by machining, subsequently blocked by spherical plugs for optimum and low-dead volume functionality
Control circuitry	1	4 different controlled systems, autonomously operating system; implemented firmware can be read or updated via PC
Pilot valve, Type 375	3	3/2-way solen. valve for neutral gases, DN 1.2 mm
Proportional valve, Type 2821	1	Direct-acting solenoid proportional valve for neutral gases and fluids; DN 0.8 mm; measuring span 1:25; hysteresis <5 %; high reproducibility and good response sensitivity
Piezo-proportional valve, Type 6115S	3	Direct-act. proport. valve with piezo-ceramic bend. element for oil-free or dry neut. gases; 10 mm width per station, DN 0.4 mm; closed-circuit curr. $\leq 0.1 \mu\text{A}$
Pressure switch, Type 1045	1	Max. 100 bar overpressure safety Setting pressure range 1 ... 10 bar
Pressure switch	2	Max. 10 bar, setting pressure range 0...6 bar Very good control characteristic
Pressure sensors	4	On-chip temperature-compensated and calibrated piezo-resistive pressure sensor, ± 0.25 linearity

12. Glossary

A

Adenine

Organic purine base, element of nucleotides

Amino acid sequence

Linear sequence of amino acids in a protein or peptide

Amino acids

Organic compounds which feature both an amino group and a carboxyl group as the characteristic feature. The 20 "natural" amino acids are joined to the ribosomes of a cell in accordance with the DNA code and form the proteins.

Antibody

The body's own immune system proteins for fighting exogenous antigens

Anticodon

Base triplet of tRNA. It serves to translate the genetic code to the ribosomes and reads the mRNA

Antigen

Foreign protein, which, once it enters the body, causes the formation of antibodies

Array

Regular two-dimensional arrangement of measuring points on a sensor. In detail: matrices made of biological material, such as DNA or proteins, which is applied in ordered patterns of high density and with equal spacings to a firm substrate. Arrays are used for efficient (parallel) investigation of a high number of biological samples.

Assay

Test system comprising targets and chemical substances evaluated by a measuring facility

Autologous

Endogenic or produced within the body

B

Bacteria

Unicellular microorganisms without nucleus. They are propagated by simple cell division. 3 basic forms: rod-shaped bacilli, ball-shaped bacilli (cocci) and curved rod-shaped bacilli (spirilla). Bacteria may be desirable (e.g. enteric bacteria or intestinal flora) or undesirable (e.g. salmonella). They are very well-suited to biotechnological production processes since they can be propagated quickly in inexpensive nutrient solutions.

Base pair

The two bases, adenine and thymine, and the two bases, cytosine and guanine; each form pairs in a DNA double strand, which are held together by weak bonds. The sum of these bonds is responsible for the coherence of the two DNA strands.

Bases

The conventional designation for the basic elements of nucleotides, the subunits of DNA and RNA. The genetic information is coded by the four DNA bases adenine (A), cytosine (C), thymine (T) and guanine (G) (see structure of DNA).

Biocontainment

See Containment

Bioreactor

A system in which microbial conversion processes of organic substances occur under controlled conditions and can be measured

Biosensors

Devices for measuring physical and chemical vital processes on and in organisms. Today, the term means a set-up in which a biological component (e.g. an enzyme, an antibody or a microorganism) is linked directly to a signal transducer (e.g. an electrode, optical fiber, piezo-crystal or transistor).

Biotechnology

Use or utilization of living organisms or their elements to produce, modify or break down substances for services (diagnostics/analytcs) or to change organisms. The term "modern biotechnology" is used for innovative methods, processes or products which include the essential utilization of living organisms or their cellular constituents.

C

cDNA

(= Complementary DNA) Single or double-strand DNA copy of an RNA

Cell

The basic unit of every organism containing genetic material, an energy-producing system and other components

Cell culture

Cultivation and propagation of cells in liquid culture media or on solid culture media, in specific vessels or systems

Cell cycle

The cycle of growth, DNA doubling, growth and cell division in the case of eukaryotes

Cell suspension

Single cells in a nutrient solution

Chromatography

A generic term covering the processes of the physical separation of substance mixtures on the basis of their differing distribution between a solid and a liquid phase

Chromosomes

A sub-unit of the genome in higher organisms. It primarily consists of DNA and protein.

Clone

A colony of genetically identical cells. They result from divisions from a single cell.

Cloning

Production of cells or entire organisms with identical genotypes. The original cell originates, for example, from an early embryonic stage. Also: production of cells containing modified genotype (hereditary substance).

Complementary DNA

cDNA, a DNA which is synthesized in a laboratory w. the aid of mRNA matrices

Containment

Prevention of the uncontrolled propagation of transgenic DNA

Codogenic strand

The strand of the double helix which contains the genetic information

Codon

Sequence of three bases (triplet) on the mRNA with information for ribosomes on protein production

Cytokines

A generic term for numerous endogenous substances which are released by immune system cells during the immune response. They are important for repair mechanisms to repair tissue damage and specifically stimulate the growth of cells. Cytokines include interleukines (IL), interferons and the growth factors GM-CSF and G-CSF (see Chapter 7).

Cytoplasm

Content of a cell, with the exception of the cell nucleus, consisting of a fluid medium and numerous cell organelles

Cytosine

Organic pyrimidine base, an element of nucleotides

Cytostatics

Substances which kill off division-active eukaryotic cells, i.e. including human cells. Cytostatics are used to treat various forms of cancer.

D

Diagnostic markers

For marking single cells which can be visualized with corresponding diagnostic methods (such as blue color when subject to UV light)

Differentiation

Higher organisms contain different types of cells that perform specialized functions. The human skin cell in must perform tasks different from those of a liver cell. The process that causes specialized cells to occur is referred to as differentiation. In higher organisms, all cell types are produced by division and differentiation from the fertilized egg cell.

DNA

Deoxyribonucleic acid. The idioplasm of all organisms (apart from viruses). DNA consists of linearly linked nucleotides, the sequence of which forms the hereditary information.

DNA clone

A section of DNA which is inserted into a vector (plasmide) in order to produce several copies.

DNA polymerase

An enzyme which catalyses the synthesis of DNA on the basis of DNA parent material (e.g. in replication). Frequently used for in-vitro synthesis of DNA sections.

DNA replication

The process of reproducing copies of DNA strands

Domain

The smallest unit of a protein with a defined and independently folded structure. Domains consist of 50 – 150 amino acids and frequently perform individual reactions whose interaction forms the overall function of a protein.

Double helix

Two DNA strands wound together helically

Dots

Measuring points with coupled biomolecules on a biochip

E

Electrophoresis

A separating method based on the migration of electrically charged colloid particles (charged electrically as the result of attachment or expulsion of ions) in an electric field. It is primarily used to separate and precipitate off small quantities of substances, e.g. DNAs.

Electroporation

A process for admitting DNA into cells using a brief electrical pulse

Elongation

The middle phase of translation. Further reading of the mRNA.

Enzymes

Proteins which act as an accelerator or promote a reaction in biological or biochemical processes

Exon

Encoding section of the gene, which bears information, which is still present in the spliced mRNA and which has not been previously cut out by enzymes. Exons define the amino acid sequence of proteins.

Expression

Conversion of genetic information into a corresponding protein

F

Fermentation

A technical process for producing or converting substances with the aid of microorganisms

Flow cytometry

Method of optical particle measurement used to identify and characterize heterogeneous cell populations

Fluorescence microscopy

A process which utilizes the phenomenon of fluorescence to sharply visualize (with high contrast), specifically selected cell constituents contrasted from other components.

Functional genomics

Analysis of the functional interplay of genetic information

G

Gel electrophoresis

A method of separating nucleic acid molecules or proteins embedded in a gel on the basis of their mobility in an electrical field

Gene

The basic unit of the hereditary information. A gene consists of a DNA section which contains the information for synthesis of an RNA. In certain cases, the RNA itself is the end product.

Generally however, it serves to transport the genetic information to the ribosomes where proteins are then formed.

Gene expression

Conversion of the genetic information from the DNA via a messenger RNA (mRNA) to a protein

Gene probe

A specifically marked single-strand nucleic acid (DNA, RNA) which can detect a specific gene and thus hybridize owing to its complementarity

Genetic code

The translation code for translation between the information units (codons) of the genes and the amino acid elements of the proteins. Apart from very slight details, the genetic code is identical on all living beings

Genetic engineering

A sub-area of biotechnology. A method which allows genes to be identified, isolated and recombined in a test tube and which allows them to be transferred in targeted manner to other organisms and produce an action there.

Genetic therapy

An attempt to heal diseases, e.g. by the introduction of intact genes into the "sick" cells. Somatic gene therapy: non-hereditary; germline therapy: hereditary.

Genome

The entirety of all the genes of an organism

Genomics

Genome research: investigation of the genes and their functions

GMP

Good Manufacturing Practices. The basic rules for production and quality inspections. Prerequisite for approval ("registration") as a medication.

H

Histones

Basic proteins from which the protein complexes of the chromosomes are built

Horizontal gene transfer

Transfer of genetic material to another, non-related species

Host cell

Cells which fungi, bacteria and viruses require in order to live

Hot spots

DNA regions susceptible to gene mutation (e.g. TT)

HPLC

High-Performance Liquid Chromatography: a chromatographic method in which liquid substances (or substances dissolved in a liquid) are transported by means of a solvent (eluent) under high pressure through a separation column, where splitting into individual components occurs at the stationary phase (over the retention times). It is used frequently as a preparation for production of pure substances.

Hybridization

Bonding of a nucleic acid single strand (DNA or RNA) by base pairing to another complementary single strand

I

Immune system

Humankind's biological defense system for protecting against the penetration of foreign substances

In silico

Literally: in silicon. Silicon is the material of which computer chips are made. Thus, in silico means: in the computer (bioinformatics).

In vitro

(= in the test tube): outside of the organism

In vivo

In the living organism

Initiation

Starting operation of translation. The ribosome unit bonds with the mRNA.

Insertion

Inserting DNA sections into another DNA molecule

Intron

Section of a gene which interrupts the coded area and which is not translated into protein

K

Kinases

A special class of enzyme which joins phosphate groups to proteins

L

LC/MS

Coupling system comprising liquid chromatography and mass spectrometry

Ligand

A natural or synthetic chemical molecule that binds selectively to a protein

Lymphocytes

A specific class of white blood corpuscles which are of importance for the immune system

M

MALDI

Matrix-Assisted Laser Desorption/Ionization; a combination of chromatography and mass spectrometry

Marker genes

A gene in plasmids or viruses serving as a marking for detection of the genetically modified object

Messenger RNA

mRNA. The RNA of a gene is transcribed to the mRNA molecules, which then serve as a blueprint for protein synthesis.

Monoclonal antibodies

Structurally identical antibody clones produced by genetic engineering

mRNA / messenger RNA

Ribonucleic acid molecule which is produced in the process of transcription from the DNA and which contains the information for synthesis of a protein

mRNA maturing/post-transcriptional processing

Processing transcribed mRNA to form the definitive version by cutting out the introns.

Multi-potency, multi-potent

The property of tissue-typical stem cells to be able to develop into different cell types of an organ

Mutation

A change in the DNA sequence that can lead to the synthesis of modified, inactive protein

N

Nucleic acid

The family of molecules which represent the building blocks of DNA and RNA molecules

Nucleoli

Areas in the nucleus in which rRNA is formed

Nucleotide

A single building block of DNA or RNA, consisting of a compound of phosphate with a sugar molecule comprising five carbon atoms (pentose) and a pyrimidine or purine base such as adenine, guanine, cytosine or thymine

Nutrient solution

Liquid nutrient media for cultivating microorganisms and cells

O

Oligonucleotide

(oligo, Greek: little or small)

A sequence of a few to several hundred interlinked nucleotides. An oligonucleotide thus corresponds to a (very) short DNA single strand.

Omnipotence, omnipotent

Designation for cells that still feature all functions of the overall organism

P

PCR (Polymerase Chain Reaction)

A process for propagating extremely small quantities of DNA on an in-vitro specific basis and identically without cloning

Peptide

A short chain of amino acids

Phages

Viruses which attack bacterial cells

Phenotype

The manifestation and specific characteristics of an organism – determined by the interaction of the genotype and the ambient influences

Phosphatases

A special class of enzymes that removes phosphate groups from proteins

Plasmides

Small annular section of DNA of bacterial origin which is capable of independent reproduction within a host organism. Most genetic engineering experiments are performed on and with plasmids.

Pluripotent, pluripotency

The potential of embryonic stem cells to mature (differentiate) in cells of different tissue types.

Polymerase

An enzyme responsible for replication of DNA

Polymerase chain reaction

See PCR

Primer

A short RNA sequence, the starter molecule for DNA replication

Promotor

A nucleotide sequence upstream of the gene which is crucial to whether the gene can be read and in what quantity it can be produced

Protein

High-molecular compound (chain) of amino acids. Very diverse tools and building blocks of cells, which may have many functions (e.g. enzymes, hormones, structure proteins, transport proteins, antibodies, neurotransmitters and receptors).

Proteomics

The investigation of proteins and their function

Protoplasts

Cells without cell walls

Purine bases

Adenine and guanine that are derived from purine

Pyrimidine bases

Cytosine, thymine and uracil which are derived from pyrimidine

R

Recombinant antibodies

Antibodies which are comprised of proteins whose hereditary information originates from different species

Recombinase

An enzyme which attacks the DNA at specific points, cuts out sequences and connects sequences together (recombines them)

Recombination

Combination of DNA of differing origin

Restriction enzymes

Enzymes which detect a short, defined nucleotide sequence on the DNA and split the DNA at this point or its vicinity

Reverse transcriptase

A viral enzyme that can rewrite RNA to DNA. It is used for in-vitro synthesis of cDNA.

Receptors

Molecules on the cell surface which are capable of binding a precisely defined molecule (their ligands)

Ribosomes

Cell organelles which serve to synthesize proteins

RNA (ribonucleic acid)

Produced by transcription of the DNA and contains, amongst other things, the information for synthesis of a protein. It occurs as mRNA, tRNA and rRNA. In contrast to DNA, it contains uracil instead of thymine. It is generally single-strand.

rRNA

Ribosomal RNA. It is involved in the structure of ribosomes.

S

Screening

Mass testing of substance banks with an assay

SELDI

Surface-Enhanced Laser

Desorption/Ionization. A combination of chromatography and mass spectrometry

Sequence analysis / sequencing

Determining the base sequence of a DNA or RNA strand or the amino acid sequence in a protein

Somatic genetic therapy

Genetic therapy on cells of a body, apart from the germ cells; non-hereditary

Specificity

The property of active substances to differentiate between different but similar target structures

Splicing

Converting a primary RNA transcript to a mature, translatable mRNA by removing intron sections

Starter codogene

Triplet at the start of a gene that determines the start of transcription on the DNA

Starter culture

A bacterial culture which performs the acidification process (e.g. for yogurt and cheese)

Structure gene

The part of a gene which contains information for the proteins

T

Target

A biological molecule, e.g. an enzyme, which plays an important role in the production or development of an illness or disease

Target molecule

The point of attack of active substances (therapeutics) in sick cells

Terminator codogene

The triplet at the end of a gene which determines the end of the transcription on the DNA

Termination

End phase of translation. Detachment of the ribosomes from the mRNA.

Thymine

Organic pyrimidine base. An element of the DNA nucleotides.

Tissue engineering

An interdisciplinary area of biotechnology. It deals with processes for in-vitro reproduction of higher cells, in particular for use of specific body tissues such as skin or cartilage

TOF

Time-Of-Flight mass spectrometer

Totipotent, totipotency

The property of early embryonic cells (generally as far as the 8-cell stage) to be able to develop to form a complete organism even after separation from the embryo

Transduction

Transfer of genes by viruses to other cells

Transformation

Natural and artificial transfer of DNA to a cell

Transgene

An organism containing foreign genes

Transcription

The first step of gene expression. An mRNA copy of an information-bearing DNA section (gene) is synthesized in the cell nucleus by an RNA polymerase enzyme complex.

Translation

Second step of gene expression. The information transferred to the mRNA is read by ribosomes and translated to the corresponding amino acid sequence (protein).

Triplet

(see codon) A sequence of 3 nucleotides within the DNA. A defined amino acid in a protein is assigned to a triplet in the DNA in accordance with the rules of the genetic code.

tRNA

Carrier molecule for amino acids during translation

U

Uracil

Pyrimidine base comprising ribonucleic acid

V

Validation

Verification of the specific action of an active substance on a target, with the aim of achieving a clear therapeutic benefit

Vector

DNA molecule (e.g. a plasmid) that can be inserted into cells and which is generally forwarded to the daughter cells by the host cells during division. Vectors are used for transfer of foreign DNA sections.

Virus

An infection particle (not a cell), consisting of a protein coat and a genome (DNA or RNA). Viruses may penetrate specific cells and insert their genotype (DNA or RNA). The genotype of the viruses can be integrated in the genome of the cell (always as DNA) and may remain ineffective for a long time. If it is activated, new viruses are produced and the host cell generally dies.

**Burkert Service and
Distribution Network**

Australia

Burkert Fluid Control Systems
No. 2 Welder Road,
Seven Hills, NSW 2147
Tel. +61 1300 888 868
Fax +61 1300 888 076

Austria

Burkert-Contromatic Ges.m.b.H.
Diefenbachgasse 1-3
1150 Wien (Vienna)
Tel. +43 (0) 1 894 13 33
Fax +43 (0) 1 894 13 00

Belgium

Burkert-Contromatic SA
Bijkhoevelaan 3
2110 Wijnegem
Tel. +32 (0) 3 325 89 00
Fax +32 (0) 3 325 61 61

Brazil

Burkert-Contromatic Brasil Ltda.
Rua Américo Brasiliense
no. 2171 cj 1007
04715-005 São Paulo - SP
Tel. +55 (0) 11 5182 0011
Fax +55 (0) 11 5182 8899

Canada

Burkert Contromatic Inc.
760 Pacific Road, Unit 3
Oakville (Ontario) L6L 6M5
Tel. +1 905 847-55 66
Fax +1 905 847-90 06

China

Burkert Contromatic (Suzhou) Co.,
Ltd.
9-2 Zhu Yuan Road,
Suzhou New District
Jiangsu, China. 215011
Tel. +86 512 6808 19 16
Fax +86 512 6824 51 06

Czech Republic

Burkert-Contromatic Ges.m.b.H.
Branch-Office Austria
Krenova 35
602 00 Brno
Tel. +42 05 43 25 25 05
Fax +42 05 43 25 25 06

Denmark

Burkert-Contromatic A/S
Hørkær 24
2730 Herlev
Tel. +45 44 50 75 00
Fax +45 44 50 75 75

Finland

Burkert Oy
Atomitie 5
00370 Helsinki
Tel. +358 (0) 9 549 70 600
Fax +358 (0) 9 503 12 75

France

Burkert Contromatic France
Rue du Giessen
BP 21
67220 Triembach au Val
Tel. +33 (0) 3 88 58 91 11
Fax +33 (0) 3 88 57 20 08

Germany

Bürkert GmbH & Co. KG
Christian-Bürkert-Straße 13-17
D-74653 Ingelfingen
Tel. +49 (0) 7940 10 111
Fax +49 (0) 7940 10 448

Hong Kong

Burkert-Contromatic (China/HK) Ltd.
Unit 708, Prosperity Centre
77-81, Container Port Road
Kwai Chung N.T., Hong Kong
Tel. +85 2 2480 1202
Fax +85 2 2418 1945

Ireland

Burkert Contromatic (Ireland) Ltd.
Penrose Wharf Centre
Penrose Wharf
Cork
Tel. +353 214 86 13 36
Fax +353 217 33 23 65

Italy

Burkert Contromatic Italiana S.p.A.
Centro Direzionale „Colombiolo“
Via Roma 74
20060 Cassina De' Pecchi (Mi)
Tel. +39 02 95 90 71
Fax +39 02 95 90 72 51

Japan

Burkert-Contromatic Ltd.
1-8-5 Asagaya Minami
Suginami-ku
Tokyo 166-0004
Tel. +81 (0) 3 5305 3610
Fax +81 (0) 3 5305 3611

Korea

Burkert Contromatic Korea Co., Ltd.
287-2, Doksan 4 Dong
Kumcheon-ku
Seoul 153-811
Tel. +82 (0) 3 3462 5592
Fax +82 (0) 3 3462 5594

Netherlands

Burkert-Contromatic BV
Computerweg 9
3542 DP Utrecht
Tel. +31 (0) 346 58 10 10
Fax +31 (0) 346 56 37 17

New Zealand

Burkert Contromatic Ltd.
2A, Unit L, Edinburgh St
Penrose, Auckland
Tel. +64 (0) 9 622 2840
Fax +64 (0) 9 622 2847

Norway

Burkert Contromatic A/S
Hvamstubben 17
2013 Skjetten
Tel. +47 63 84 44 10
Fax +47 63 84 44 55

Philippines

Burkert Contromatic Philippines, Inc.
8467 West Service Road
South Superhighway, Sunvalley
Paranaque City, Metro Manila
Tel. +63 2 776 43 84
Fax +63 2 776 43 82

Poland

Burkert-Contromatic Ges.m.b.H.
Branch-Office Austria
Bernardynska street 14 a
02-904 Warszawa
Tel. +48 22 840 60 10
Fax +48 22 840 60 11

Portugal

Burkert Contromatic
Tel. +351 21 382 80 00
Fax +351 21 387 36 79

Singapore

Burkert Contromatic
Singapore Pte. Ltd.
51 Ubi Avenue 1, #03-14
Paya Ubi Industrial Park
Tel. +65 6844 2233
Fax +65 6844 3532

South Africa

Burkert Contromatic (Pty) Ltd.
94 Griffiths Road
Jetpark
Tel. +27 (0) 11 397 2900
Fax +27 (0) 11 397 4428

from 01.07.2003

233 Albert Amon Road
Millenium Business Park
Meadowale
Edenvale
Tel. +27 (0) 11 397 2900
Fax +27 (0) 11 397 4428

Spain

Burkert Contromatic S.A.
Avda. Barcelona, 40
08970 Sant Joan Despi (Barcelona)
Tel. +34 93 477 79 80
Fax +34 93 477 79 81

Sweden

Burkert-Contromatic AB
Skeppsbron 13 B
211 20 Malmö
Tel. +46 (0) 40 664 51 00
Fax +46 (0) 40 664 51 01

Switzerland

Burkert-Contromatic AG Schweiz
Bösch 71
6331 Hünenberg
Tel. +41 (0) 41 785 66 66
Fax +41 (0) 41 785 66 33

Taiwan

Burkert Contromatic Taiwan Ltd.
3F, No. 475, Kuang-Fu South Road
Taipei, Taiwan
Tel. +886 (0) 2 2758 3199
Fax +886 (0) 2 2758 2499

Turkey

Burkert Contromatic Akiskan
Kontrol Sistemleri Ticaret A.S.
1203/8 Sok. No 2-E
Yenisehir, Izmir
Tel. +90 (0) 232 459 53 95
Fax +90 (0) 232 459 76 94

United Kingdom

Burkert Fluid Control Systems
Brimscombe Port Business Park
Brimscombe, Stroud, Glos., GL5 2QF
Tel. +44 (0) 1453 73 13 53
Fax +44 (0) 1453 73 13 43

USA

Burkert Contromatic USA
2602 McGaw Avenue
Irvine, CA 92614
U.S.A.
Tel. +1 949 223 3100
Fax +1 949 223 3198

Information paves the path to the appropriate system solution. We provide five different levels for accessing information, products and services, so that you can easily find out everything you need to know to make the right choice.

Service brochure

A systematic overview of the range of products and services offered by Bürkert. A network of comprehensive solutions integrating coordinated services.



Competence brochures

Essential information for the person planning control loops and field bus systems and who wants to ensure basic knowledge of the structure and selection of system components.



Application brochures

Example applications for deriving the appropriate system solution, supplemented by information on product advantages, user advantages and the range of products specifically available.



System catalogs

Background knowledge on product technology, including an up-to-date overview of the current offers. Rounded out with information to help you make your decision on the best application option.

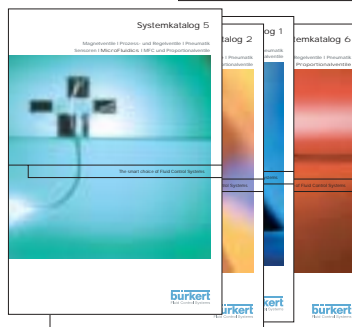

Technical data sheets

Detailed technical information for checking specific suitability. In addition, all the data needed for direct ordering.



